

PART LIST
MODEL:LD-1340E
LD-1440E
LD-1440V

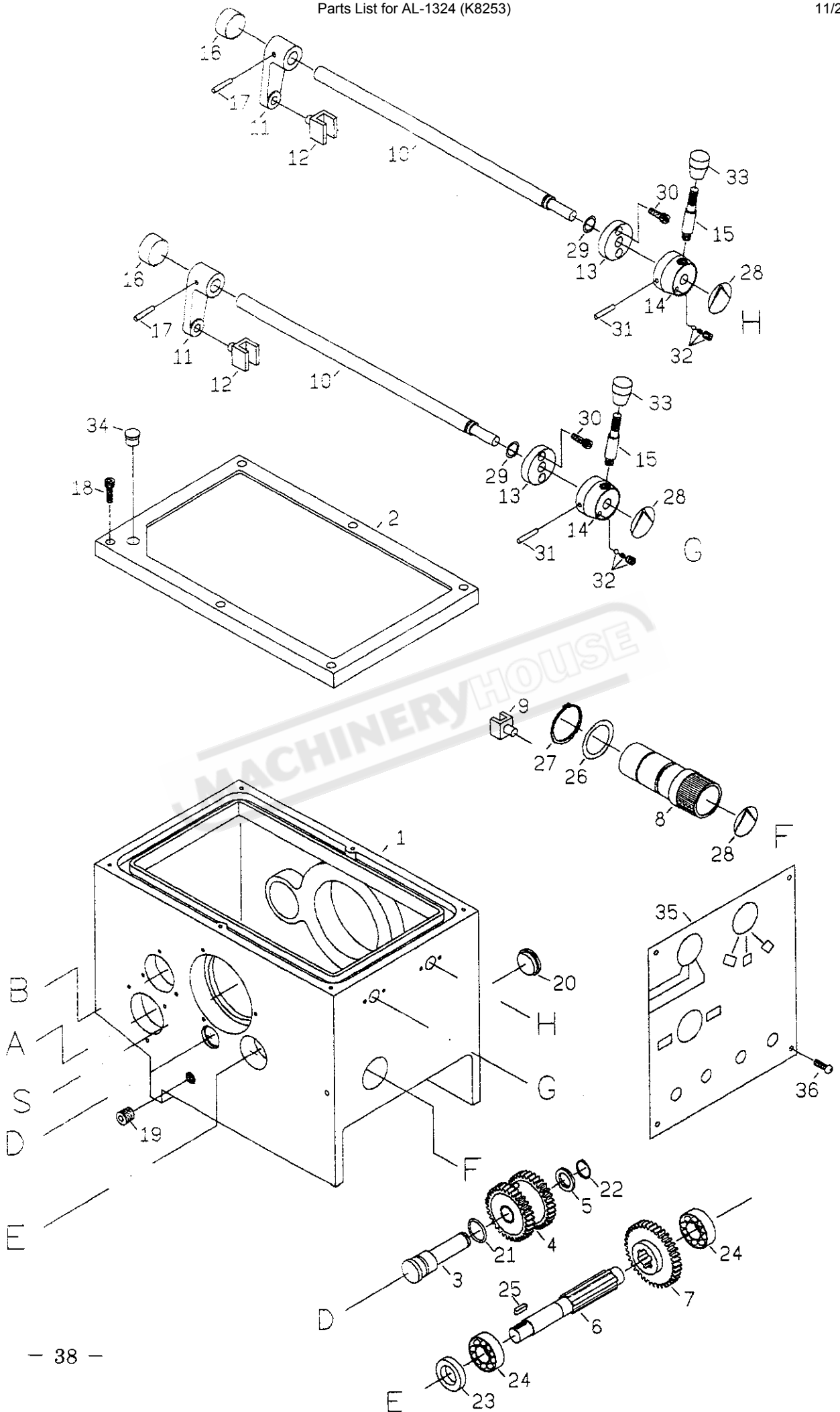

REF	QTY	DESCRIPTION
1	1	...
2	1	...
3	1	...
4	1	...
5	1	...
6	1	...
7	1	...
8	1	...
9	1	...
10	1	...
11	1	...
12	1	...
13	1	...
14	1	...
15	1	...
16	1	...
17	1	...
18	1	...
19	1	...
20	1	...
21	1	...
22	1	...
23	1	...
24	1	...
25	1	...
26	1	...
27	1	...
28	1	...
29	1	...
30	1	...
31	1	...
32	1	...
33	1	...
34	1	...
35	1	...
36	1	...

HEADSTOCK (CASTING & CONTROLS)

REF.NO.	PART NO.	DESCRIPTION	Q'TY	REMARKS
1	2101	HEADSTOCK CASTING	1	
2	2143	HEADSTOCK COVER	1	
3	2121	SHAFT	1	
4	2122	GEAR (M2X32T)	1	
5	2123	WASHER	1	
6	2124	SHAFT	1	
7	2125	GEAR (M2X38T)	1	
8	2126	HANDLE	1	
9	2127	GEAR SHIFT FORK	1	
10	2136	SHAFT	2	
11	2137	FORK ARMS	2	
12	2138	GEAR SHIFT FORK	2	
13	2139	COLLAR	2	
14	2141	HANDLE	2	
15	2142	CONTROL LEVER	2	
16	2194	OIL RING	2	
17	2193	PIN (5mmx32mm)	2	
18	2184	CAP SCREW (6mmx25mm)	6	
19	2195	PLUG (3/8 G.P.)	1	
20	2144	OIL SIGHT(29mm)	1	
21	2181	OIL RING(P20)	1	
22	2148	SNAP RING (S18)	1	
23	2178	WASHER	1	
24	2180	BEARING (6004)	2	
25	2145	KEY(5mmx18mm)	1	
26	2146	OIL RING (P12)	1	
27	2188	SNAP RING (S40)	1	
28	2185	INDICATOR PLATE	3	
29	2191	OIL RING (P12)	2	
30	2189	CAP SCREW (6mmx16mm)	4	
31	2192	SPRING PIN (5mmx40mm)	2	
32	2186	STEEL BALL SPRING & SET SCREW	2	8mmx6mm
33	2190	PVC KNOB	2	
34	2183	PLUG (5/8")	1	
35	2196	DATA PLATE	1	
36	2197	SCREW (3/16"x3/8")	4	

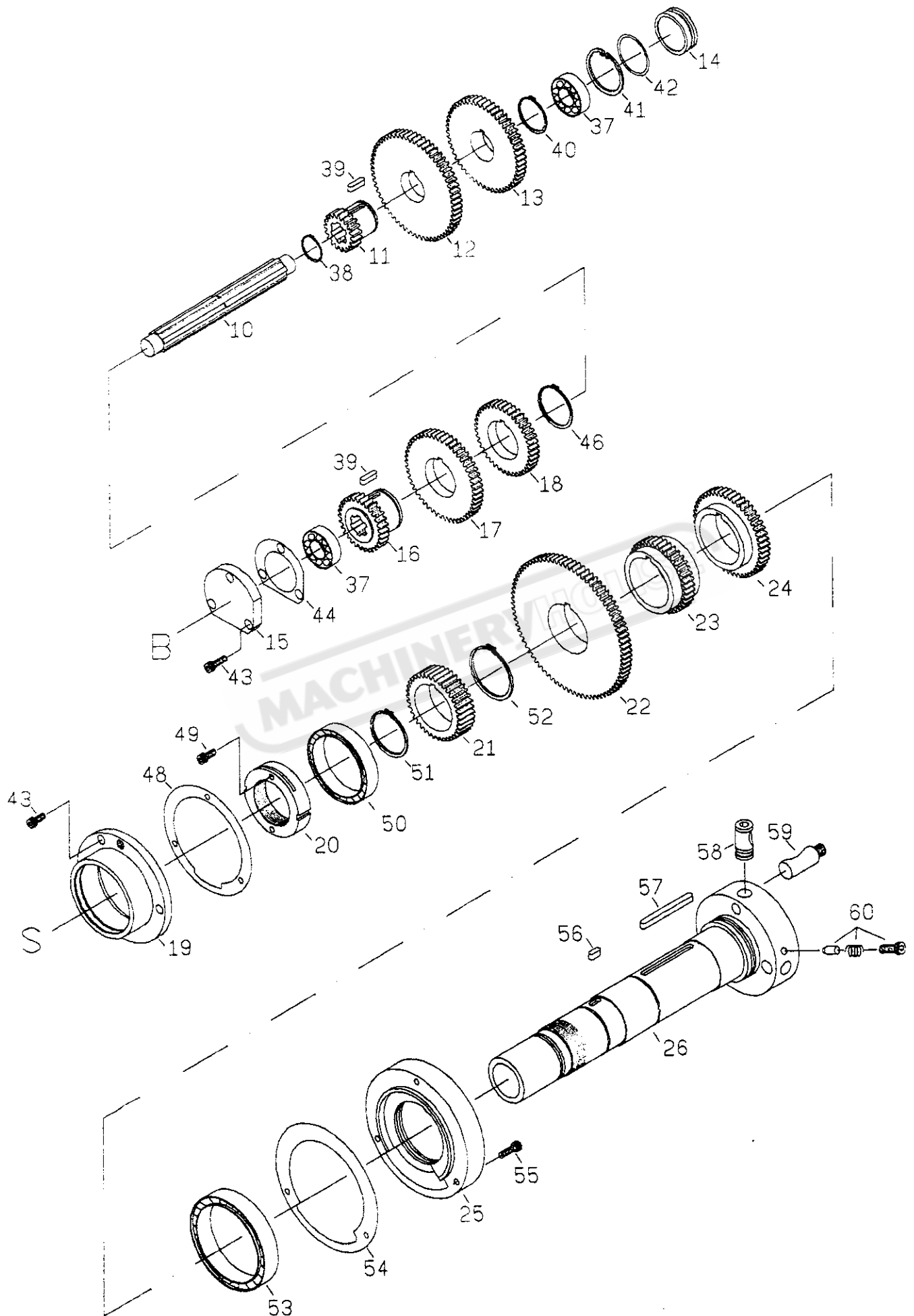

REF

10
11
12
13
14
15
16
17
18
19
20
21
22
23
24
25
26
37
38
39
40
41
42
43
44
46
48
49
50
51
52
53
54
55
56
57
58
59
60

HEADSTOCK (SPINDLE & GEARS)

NO.	PART NO.	DESCRIPTION	Q'TY	REMARKS
	2112	SHAFT	1	
	2116	GEAR (M2x19T)	1	
	2117	GEAR (M2x60T)	1	
	2118	GEAR (M2x52T)	1	
	2119	BORE PLUG	1	
	2120	COVER	1	
	2113	GEAR (M2x30T)	1	
	2114	GEAR (M2x50T)	1	
	2115	GEAR (M2x40T)	1	
	2135	COVER (BACK)	1	
	2134	LOCK NUT	1	
	2133	GEAR (M2x38T)	1	
	2132	GEAR (M2x80T)	1	
	2131	GEAR (M2x39T)	1	
	2130	GEAR (M2x48T)	1	
	2128	COVER (FRONT)	1	
	2129	MAIN SPINDLE	1	
	2162	SNAP RING (S25)	1	
	2163	KEY (6mmx22mm)	2	
	2158	BEARING (#6204)	2	
	2164	SNAP RING (S35)	1	
	2165	SNAP RING (R47)	1	
	2166	OIL RING (P39.4)	1	
	2159	SCREW (CAP 6mmx16mm)	6	
	2180	GASKET	1	
	2161	SNAP RING (S45)	1	
	2167	GASKET	1	
	2147	SCREW (CAP 6mmx25mm)	2	
	2168	BEARING (#30211)	1	
	2169	SNAP RING (S55)	1	
	2170	SNAP RING (S58)	1	
	2171	BEARING (#30212)	1	
	2172	GASKET	1	
	2173	SCREW (CAP 6mmx25mm)	3	
	2174	KEY (6mmx15mm)	1	
	2175	KEY (7mmx75mm)	1	
	2176	CAM D1-4	3	
	2182	STUD	3	
	2177	DETENT PLUNGER,SPRING AND SCREW	3	

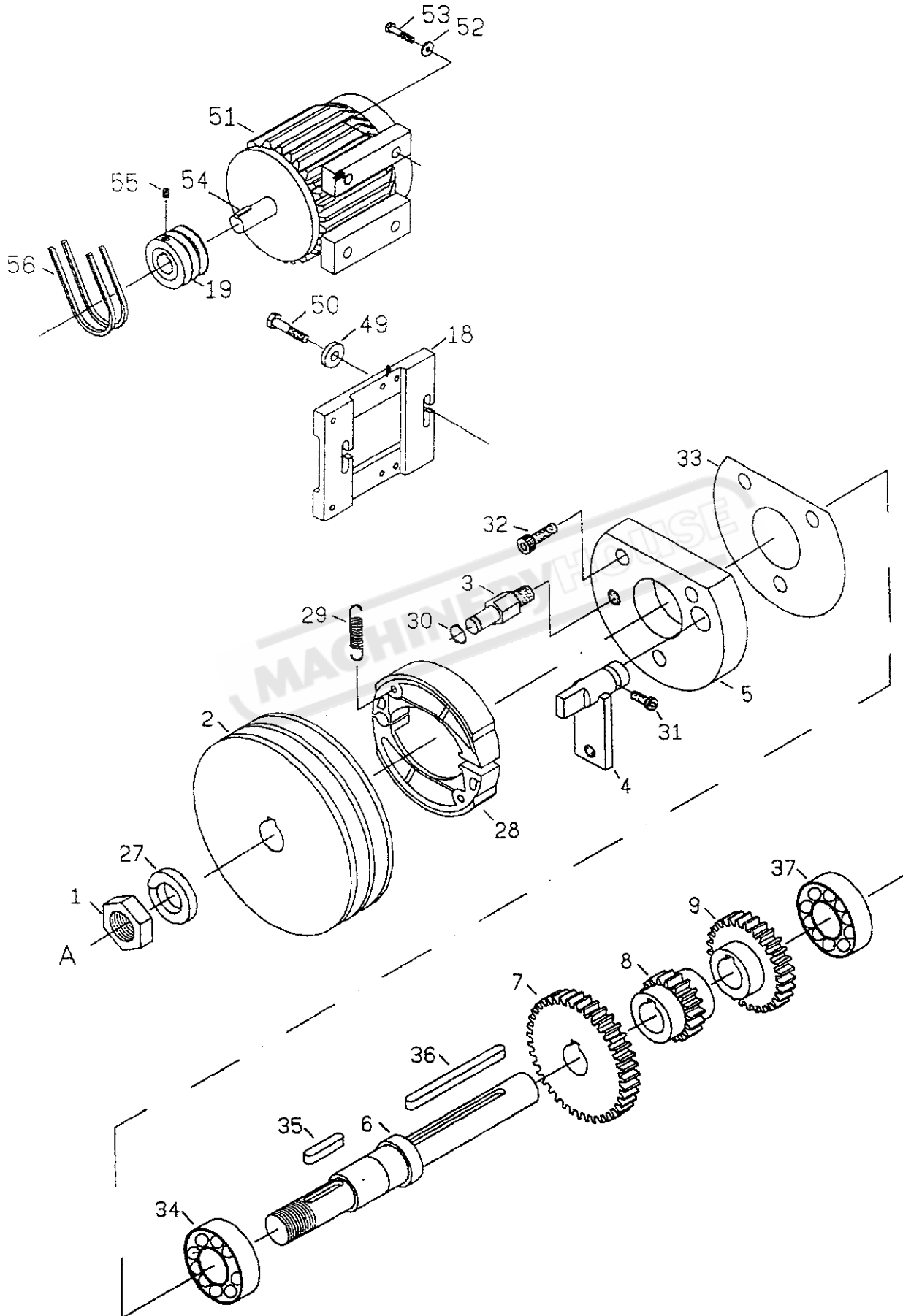

REF. N

- 1
- 2
- 3
- 4
- 5
- 6
- 7
- 8
- 9
- 18
- 19
- 27
- 28
- 29
- 30
- 31
- 32
- 33
- 34
- 35
- 36
- 37
- 49
- 50
- 51
- 52
- 53
- 54
- 55
- 56

MAIN MOTOR AND BRAKE SHOES ASSY

EF.NO.	PART NO.	DESCRIPTION	Q'TY	REMARKS
1	2111	NUT (M2xP1.5mm)	1	
2	2110	V-BELT PULLEY	1	
3	2107	STUD	1	
4	2108	SHAFT LEVER	1	
5	2106	COVER	1	
6	2102	SHAFT	1	
7	2103	GEAR (M2x39T)	1	
8	2104	GEAR (M2x18T)	1	
9	2105	GEAR (M2x29T)	1	
18	2618	MOTOR PLATE	1	
19	2653	MOTOR PULLEY	1	
27	2149	WASHER	1	
28	2109	BRAKE SHOES ASSY	1	
29	2140	SPRING	2	
30	2151	SNAP RING	1	
31	2153	CAP SCREW	1	
32	2152	SCREW (CAP 6mmx25mm)	3	
33	2179	GASKET	1	
34	2155	BEARING (#6205)	1	
35	2156	KEY (6mmx30mm)	1	
36	2157	KEY (6mmx80mm)	1	
37	2158	BEARING (#6204)	1	
49	2619	WASHER	2	
50	2631	SCREW (CAP 10mmx35mm)	2	
51	2652	MAIN MOTOR	1	
52	2656	WASHER	4	
53	2657	SCREW (CAP 8mmx30mm)	4	
54	2659	KEY (8mmx45mm)	1	
55	2655	SCREW (SET 10mmx20mm)	1	
56	2654	V-BELT	2	

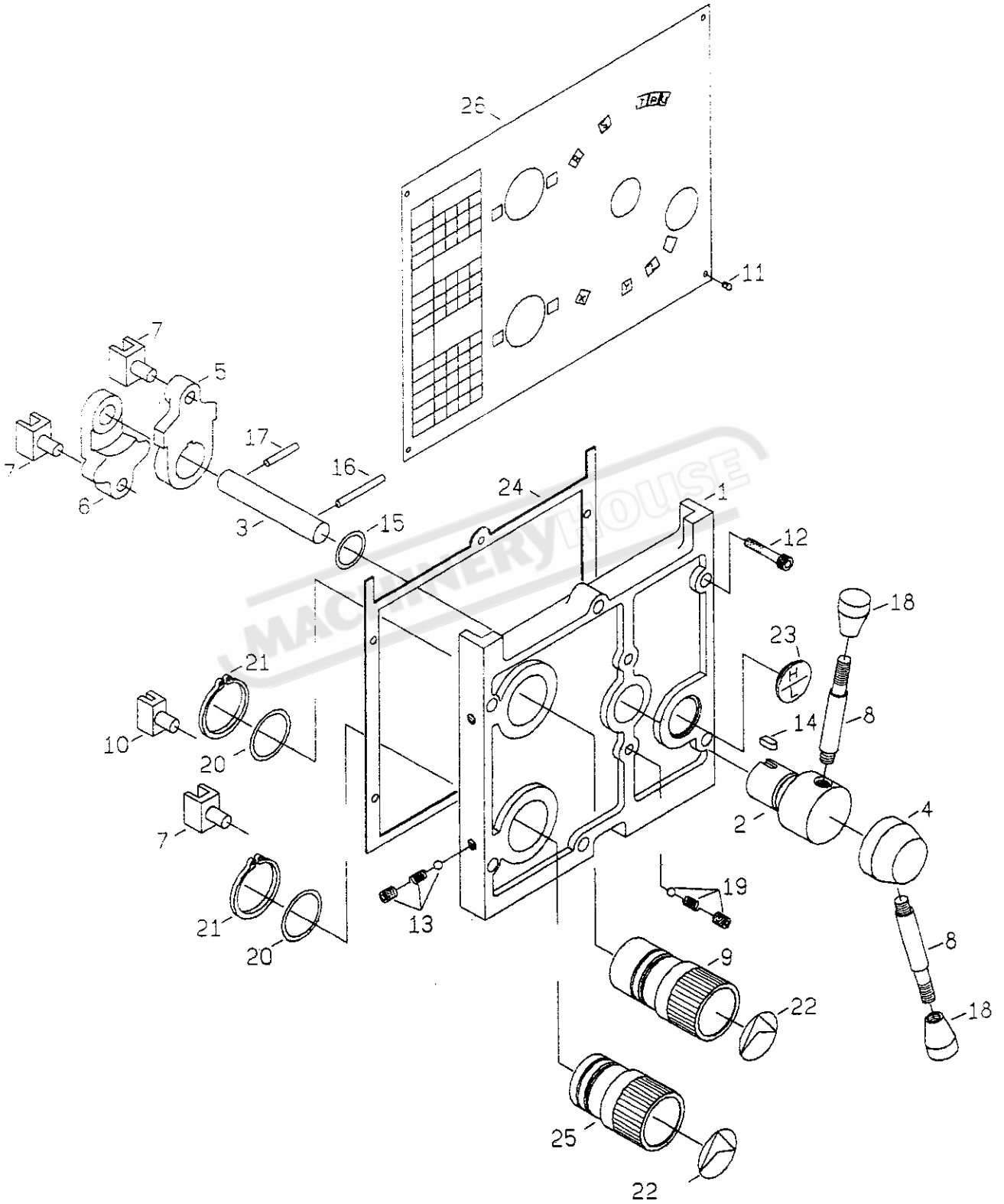

GEARBOX (CASTING & CONTROLS)

REF.NO.	PART NO.	DESCRIPTION	Q'TY	REMARKS
1	2224	COVER	1	
2	2225	HANDLE	1	
3	2226	SHAFT	1	
4	2227	HANDLE	1	
5	2228	SHIFT LEVER	1	
6	2229	SHIFT LEVER	1	
7	2230	SHIFT FORK	3	
8	2231	LEVER	2	
9	2233	HANDLE	1	
10	2234	SHIFT FORK	1	
11	2241	SCREW (3/16x3/8 IN)	6	
12	2248	SCREW (CAP 6mmx30mm)	6	
13	2247	SET SCREW SPRING AND STEEL BALL	2	
14	2251	KEY (5mmx10mm)	1	
15	2244	OIL RING (P24)	1	
16	2243	SPRING PIN (5mmx40mm)	1	
17	2242	SPRING PIN (5mmx30mm)	1	
18	2250	PVC KNOB	2	
19	2253	SET SCREW SPRING AND STEEL BALL	2	
20	2246	OIL RING (P34)	2	
21	2245	SNAP RING (S40)	2	
22	2249	INDEXING PLATE	2	
23	2252	OIL SIGHT (29mm)	1	
24	2254	GASKET	1	
25	2232	HANDLE	1	
26	2240	DATA PLATE	1	

INCH TYPE

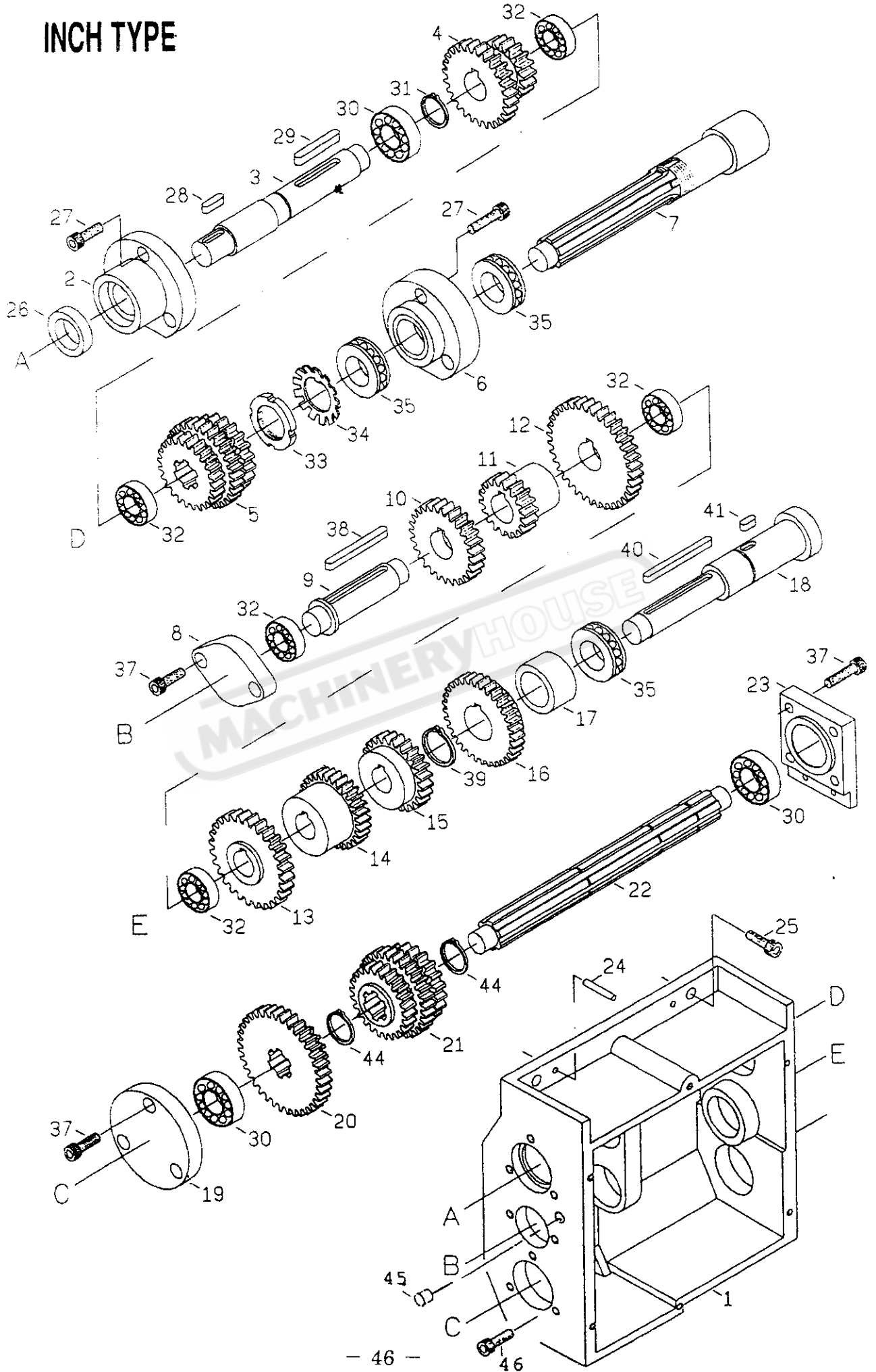

GEARBOX (GEAR & SHAFT) INCH TYPE

REF.NO.	PART NO.	DESCRIPTION	Q'TY	REMARKS
1	2201	GEAR BOX CASTING	1	
2	2204	COVER	1	
3	2202	SHAFT	1	
4	2203	GEAR (M2x27TX18T)	1	
5	2236	GEAR (14Px27Tx30T)(M2.25x21T)	1	
6	2205	COVER	1	
7	2206	SHAFT	1	
8	2218	COVER	1	
9	2208	SHAFT	1	
10	2209	GEAR (M2x27T)	1	
11	2210	GEAR (M2x18T)	1	
12	2211	GEAR (M2x36T)	1	
13	2217	GEAR (M2.25x28T)	1	
14	2216	GEAR (14Px30T)	1	
15	2215	GEAR (14Px24T)	1	
16	2237	GEAR (14Px33T)	1	
17	2212	SPACER	1	
18	2213	SHAFT	1	
19	2222	COVER	1	
20	2220	GEAR (M2x36Tx18T)	1	
21	2235	GEAR (14Px24Tx30T)(M2.25x20T)	1	
22	2219	SHAFT	1	
23	2223	COVER	1	
24	2272	PIN (5mmx28mm)	2	
25	2273	CAP SCREW (8mmx30mm)	3	
26	2256	OIL SEAL (22x35x7)	1	
27	2255	CAP SCREW (6mmx20mm)	6	
28	2267	KEY (5mmx18mm)	1	
29	2258	KEY (6mmx40mm)	1	
30	2259	BEARING (6004)	3	
31	2260	SNAP RING (S20)	1	
32	2261	BEARING (6003)	5	
33	2262	NUT	1	
34	2269	WASHER	1	
35	2263	THRUST (51105)	3	
37	2275	CAP SCREW (6mmx20mm)	9	
38	2268	KEY (6mmx55mm)	1	
39	2266	SNAP RING (S25)	1	
40	2264	KEY (5mmx60mm)	1	
41	2265	KEY (5mmx12mm)	1	
44	2274	SNAP RING (S22)	2	
45	2276	OILER (5/16 IN)	1	
46	2277	SCREW (CAP 8mmx10mm)	1	

METRIC TYPE

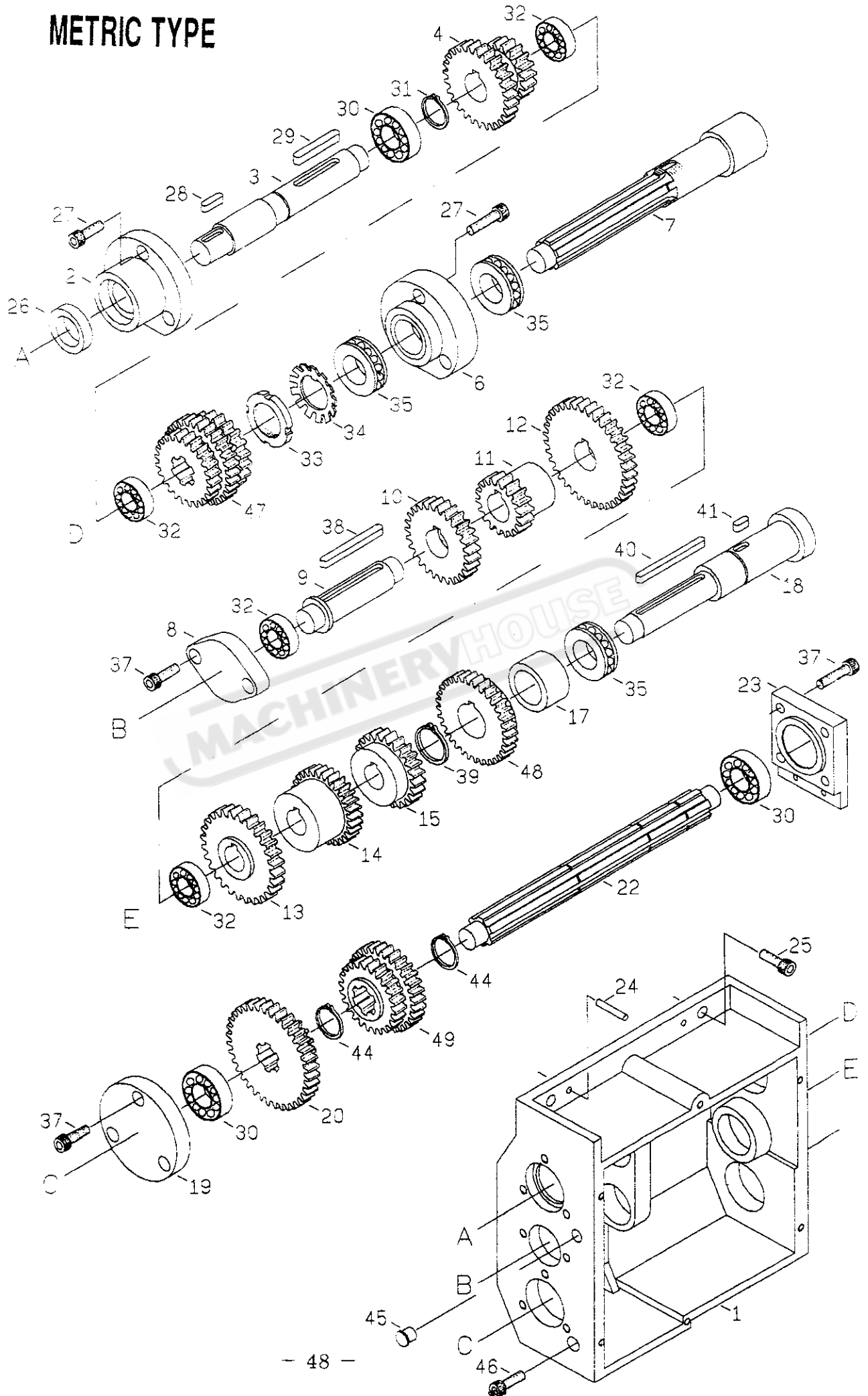

GEARBOX (GEAR & SHAFT) METRIC TYPE

REF.NO.	PART NO.	DESCRIPTION	Q'TY	REMARKS
1	2201	GEAR BOX CASTING	1	
2	2204	COVER	1	
3	2202	SHAFT	1	
4	2203	GEAR (M2x27TX18T)	1	
47	2207	GEAR (M2.25x20T)(14Px30T)(M2x25T)	1	
6	2205	COVER	1	
7	2206	SHAFT	1	
8	2218	COVER	1	
9	2208	SHAFT	1	
10	2209	GEAR (M2x27T)	1	
11	2210	GEAR (M2x18T)	1	
12	2211	GEAR (M2x36T)	1	
13	2217	GEAR (M2.25x28T)	1	
14	2216	GEAR (14Px30T)	1	
15	2215	GEAR (14Px24T)	1	
48	2214	GEAR (M2x30T)	1	
17	2212	SPACER	1	
18	2213	SHAFT	1	
19	2222	COVER	1	
20	2220	GEAR (M2x36Tx18T)	1	
49	2221	GEAR (M2.25x21T)(14Px30T)	1	
22	2219	SHAFT	1	
23	2223	COVER	1	
24	2272	PIN (5mmx28mm)	2	
25	2273	CAP SCREW (8mmx30mm)	3	
26	2256	OIL SEAL (22x35x7)	1	
27	2255	CAP SCREW (6mmx20mm)	6	
28	2267	KEY (5mmx18mm)	1	
29	2258	KEY (6mmx40mm)	1	
30	2259	BEARING (6004)	3	
31	2260	SNAP RING (S20)	1	
32	2261	BEARING (6003)	5	
33	2262	NUT	1	
34	2269	WASHER	1	
35	2263	THRUST (51105)	3	
37	2275	CAP SCREW (6mmx20mm)	9	
38	2268	KEY (6mmx55mm)	1	
39	2266	SNAP RING (S25)	1	
40	2264	KEY (5mmx60mm)	1	
41	2265	KEY (5mmx12mm)	1	
44	2274	SNAP RING (S22)	2	
45	2276	OILER (5/16 IN)	1	
46	2277	SCREW (CAP 8mmx10mm)	1	

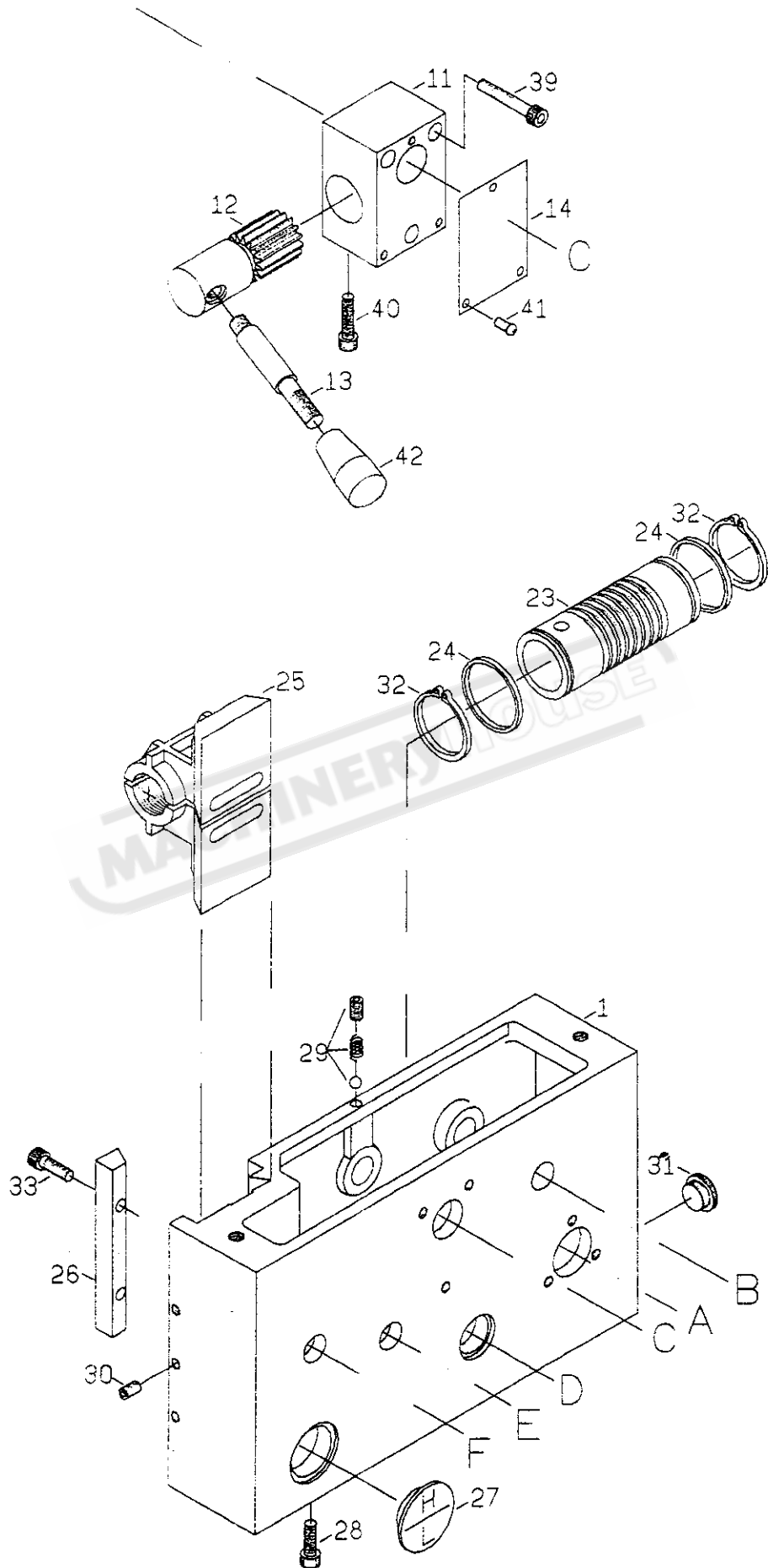

APRON (CASTING)

REF.NO.	PART NO.	DESCRIPTION	Q'TY	REMARKS
1	2301	APRON CASTING	1	
11	2316	BRACKET	1	
12	2317	GEAR SHAFT (M1.5x16T)	1	
13	2318	LEVER	2	
14	2362	INDEXING PLATE	1	
23	2309	WORM	1	
24	2310	COLLAR	2	
25	2325	HALF NUT CLUTCH	1	
26	2326	GIB	1	
27	2358	OIL SIGHT (29mm)	1	
28	2357	CAP SCREW (8mmx10mm)	1	
29	2355	STEEL BALL SET SCREW AND SPRING	1	
30	2354	SET SCREW (6mmx10mm)	3	
31	2356	PLUG (5/8 IN)	1	
32	2352	SNAP RING (S 30)	2	
33	2353	CAP SCREW (6mmx20mm)	2	
39	2363	CAP SCREW (6mmx40mm)	4	
40	2360	CAP SCREW (8mmx25mm)	1	
41	2361	SCREW (3/16x3/8 IN)	3	
42	2359	PVC KNOB	2	

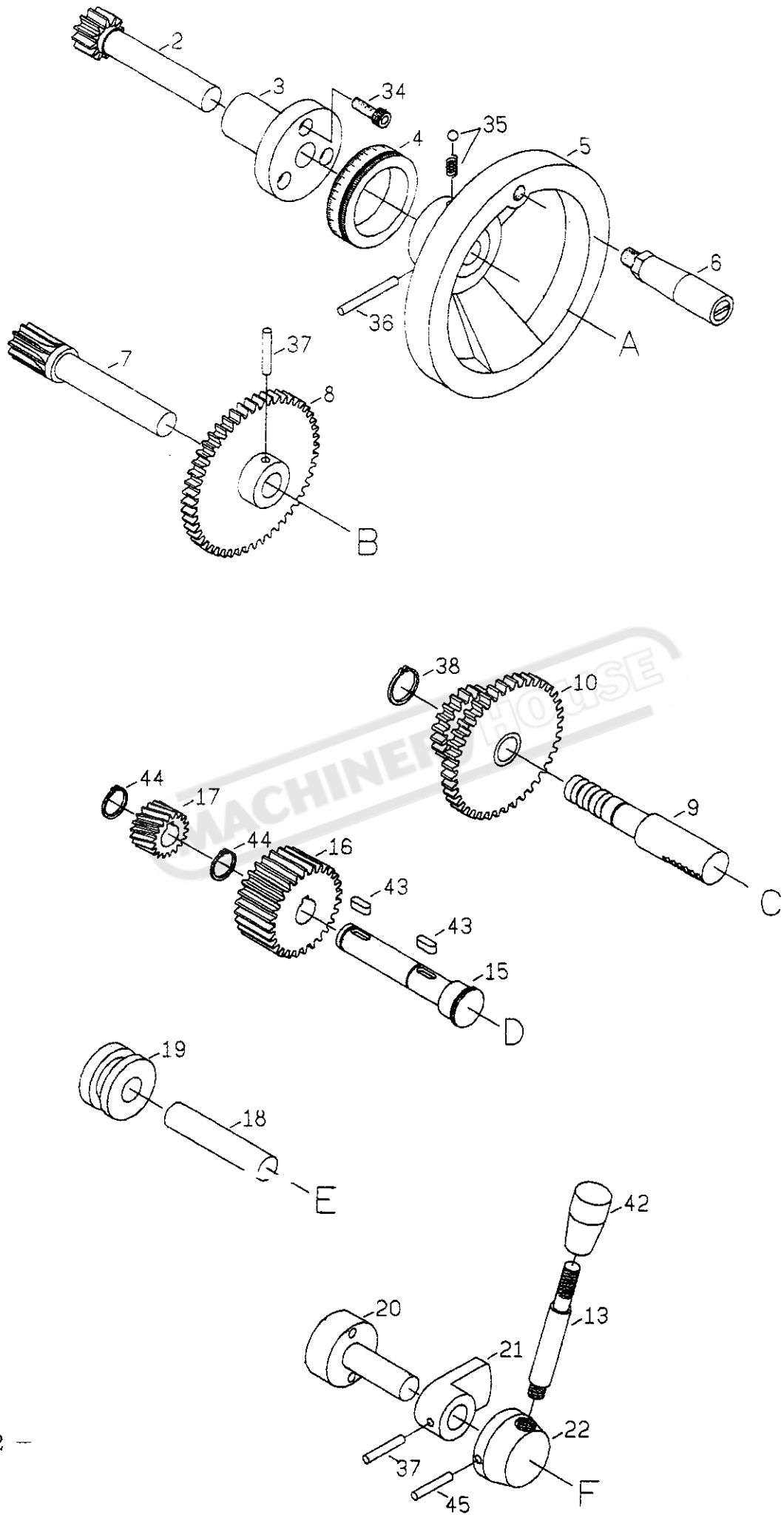

APRON (GEAR & SHAFT)

REF.NO.	PART NO.	DESCRIPTION	Q'TY	REMARKS
2	2302	GEAR SHAFT(M2x12T)	1	
3	2303	KEEP ASSY	1	
4	2304	INDEX RING	1	
5	2305	HANDWHEEL	1	
6	2306	HANDLE	1	
7	2307	GEAR SHAFT (M1.5x13T)	1	
8	2308	GEAR (M2x50T)	1	
9	2314	SHAFT	1	
10	2315	GEAR(M2x22T)(M2x44T)	1	
15	2311	SHAFT	1	
16	2312	GEAR(M2x22T)	1	
17	2313	GEAR(M1.5x18T)	1	
18	2319	SHAFT	1	
19	2320	COLLAR	1	
20	2321	SHAFT	1	
21	2322	LEVER	1	
22	2323	HANDLE	1	
34	2340	CAP SCREW(6mmx16mm)	3	
35	2341	STEEL BALL AND SPRING	1	
36	2342	PIN (5mmx50mm)	1	
37	2343	PIN (5mmx30mm)	2	
38	2344	CIRCLIP (E12)	1	
43	2348	KEY (5mmx14mm)	2	
44	2346	SNAP RING (S14)	2	
45	2351	PIN (5mmx40mm)	1	

INCH TYPE(LEADSCREW 4TPI)

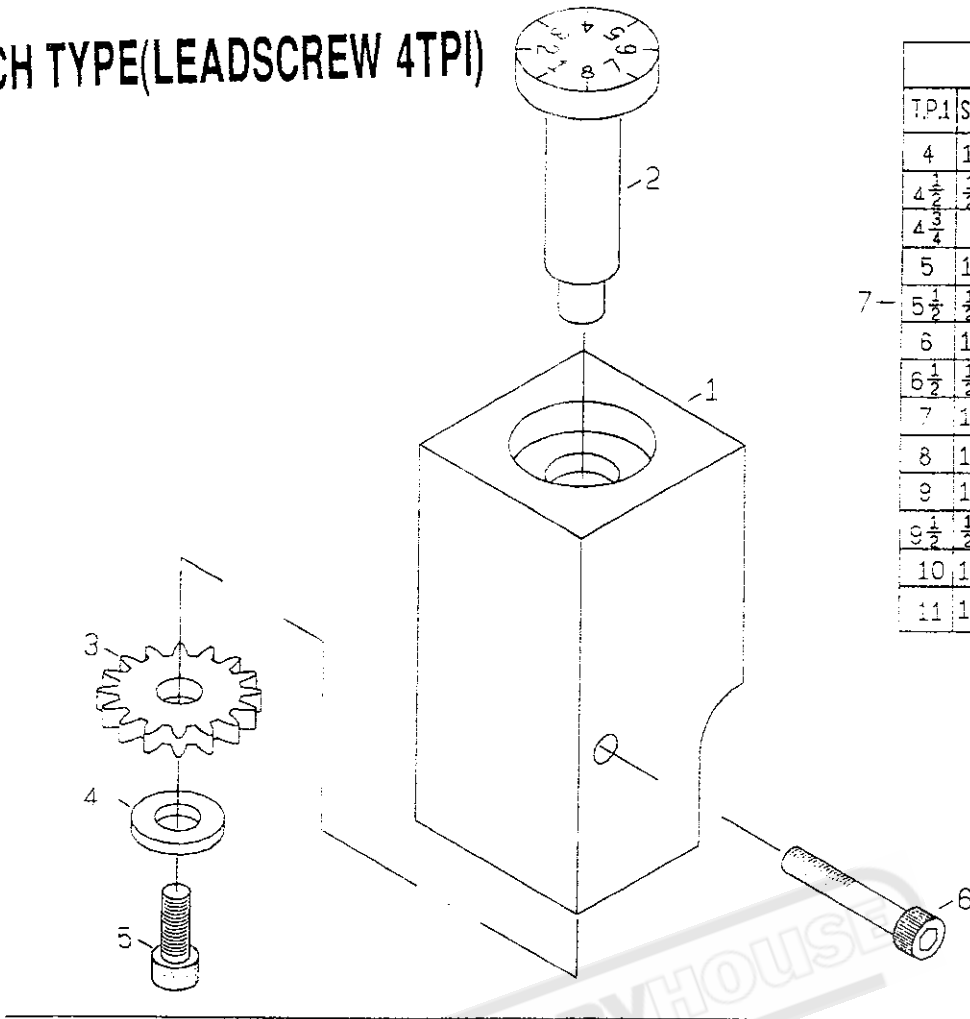

INDICATOR TABLE					
T.P.1	SCALE	T.P.1	SCALE	T.P.1	SCALE
4	1-8	12	1-8	38	
4 $\frac{1}{2}$	$\frac{1}{2}, \frac{3}{4}$	13	1-4	40	
4 $\frac{3}{4}$	1	14		44	
5	1-4	16	1-8	48	
5 $\frac{1}{2}$	$\frac{1}{2}, \frac{3}{4}$	18		52	
6	1-8	19	1-4	56	1-3
6 $\frac{1}{2}$	$\frac{1}{2}, \frac{3}{4}$	20		64	
7	1-4	22		72	
8	1-8	24	1-8	76	
9	1-4	26		80	
9 $\frac{1}{2}$	$\frac{1}{2}, \frac{3}{4}$	28		96	
10	1-8	32		104	
11	1-4	36		112	

METRIC TYPE(LEADSCREW PICH 4MM)

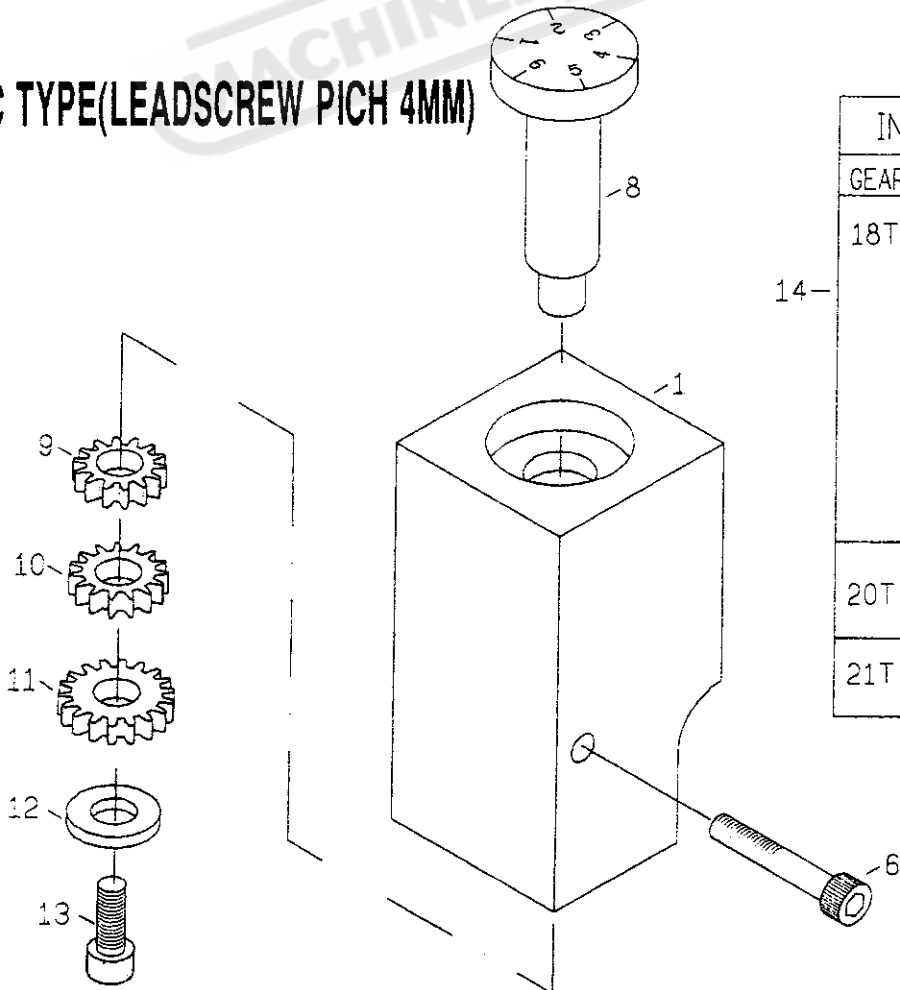

INDICATOR TABLE			
GEAR	PITCH		SCALE
18T	0.45	0.9	1, 4
	0.3	0.6	13, 5
	0.25	0.75	
	0.5	1.5	
	1	3	1-6
20T	6		
	1.25	60	1, 4
21T	2.5		
	1.75	70	1, 3, 5
	3.5		

THREADING INDICATOR

REF.NO.	PART NO.	DESCRIPTION	Q'TY	REMARKS
1	2327	THREAD BODY INDICATOR	1	
2	2328	THREAD DIAL BODY (INCH TYPE)	1	
3	2329	GEAR (M2x16T)	1	
4	2366	FLAT WASHER	1	
5	2365	CAP SCREW (6mmx12mm)	1	
6	2364	CAP SCREW (6mmx45mm)	1	
7	2336	THREAD CHART PLATE (IN TYPE)	1	
8	2328-1	THREAD DIAL BODY (METRIC TYPE)	1	
9	2330	GEAR (M1.25x18T)	1	
10	2331	GEAR (M1.25x20T)	1	
11	2332	GEAR (M1.25x21T)	1	
12	2366	FLAT WASHER	1	
13	2365	CAP SCREW (6mmx12mm)	1	
14	2337	THREAD CHART PLATE (METRIC TYPE)	1	

MACHINERYHOUSE

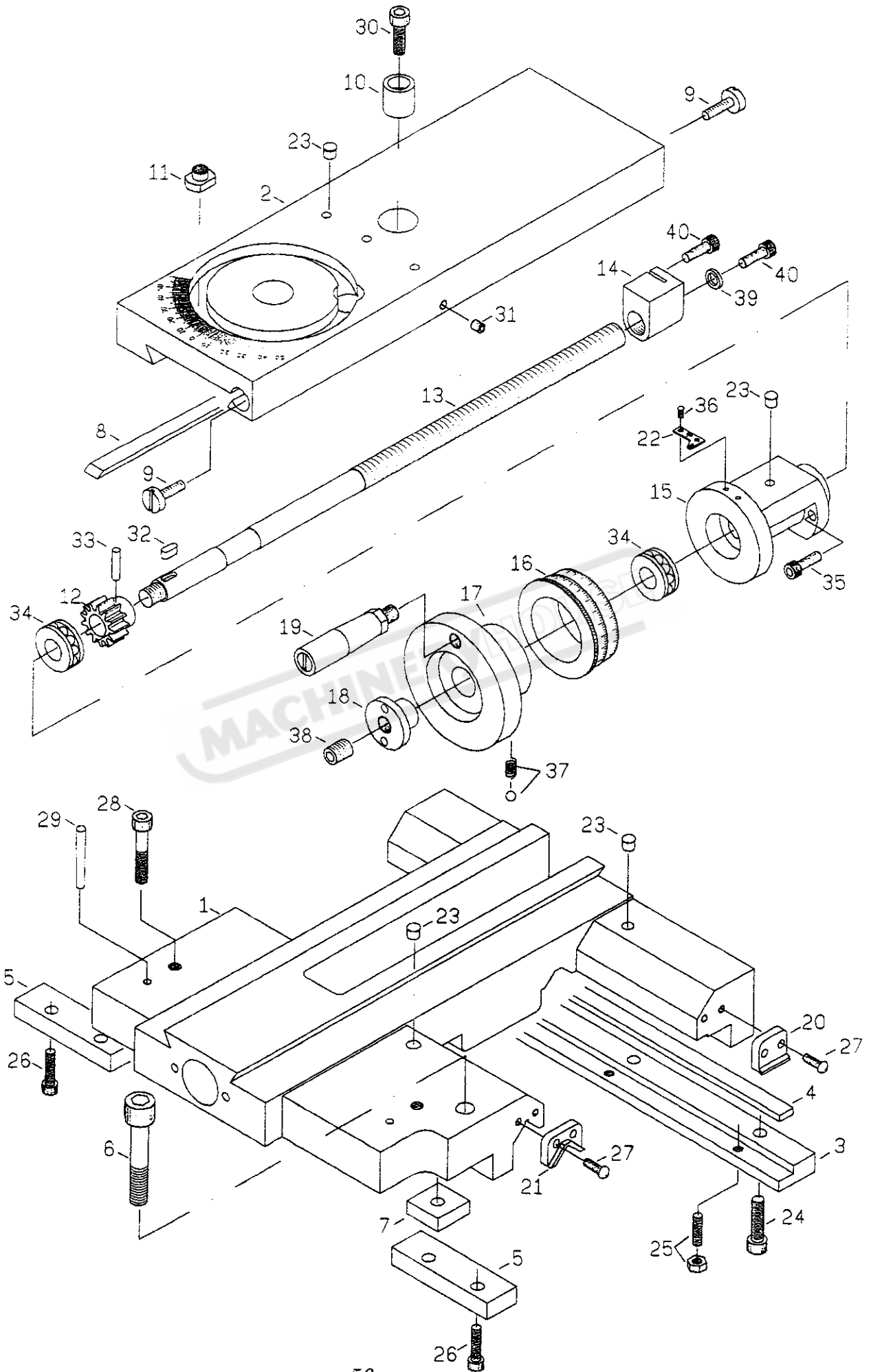

SADDLE & CROSS-SLIDE

REF.NO.	PART NO.	DESCRIPTION	Q'TY	REMARKS
1	2401	SADDLE CASTING	1	
2	2402	CROSS-SLIDE	1	
3	2403	CLAMP REAR	1	
4	2404	GIB	1	
5	2405	CLAMP FRONT	2	
6	2406	CAP SCREW (7/16x2-1/2 IN)	1	
7	2407	WASHER	1	
8	2408	GIB	1	
9	2409	GIB SCREW	2	
10	2410	COLLAR	1	
11	2419	NUT	2	
12	2411	GEAR (M2x13T)	1	
13	2412	SCREW	1	
14	2413	NUT	1	
15	2414	KEEP ASSY	1	
16	2415	INDEX RING	1	
17	2417	HANDWHEEL	1	
18	2416	PLUG	1	
19	2418	HANDLE	1	
20	2439	WIPER	2	
21	2440	WIPER	2	
22	2465	DIAL	1	
23	2450	OILER (1/4 IN)	5	
24	2454	CAP SCREW (8mmx20mm)	3	
25	2453	SCREW AND NUT	1	
26	2451	CAP SCREW (8mmx16mm)	2	
27	2452	SCREW (3/16x1/2 IN)	8	
28	2466	CAP SCREW	2	
29	2467	PIN	2	
30	2462	CAP SCREW (8mmx20mm)	1	
31	2461	CAP SCREW (8mmx20mm)	1	
32	2460	KEY (5mmx12mm)	1	
33	2459	PIN (5mmx22mm)	1	
34	2457	THRUST (2902)	2	
35	2458	CAP SCREW (6mmx25mm)	2	
36	2468	NAIL (2mm)	2	
37	2456	STEEL BALL AND SPRING	1	
38	2455	SCREW (12mmx12mm)	1	
39	2464	WASHER	1	
40	2463	CAP SCREW (6mmx12mm)	2	

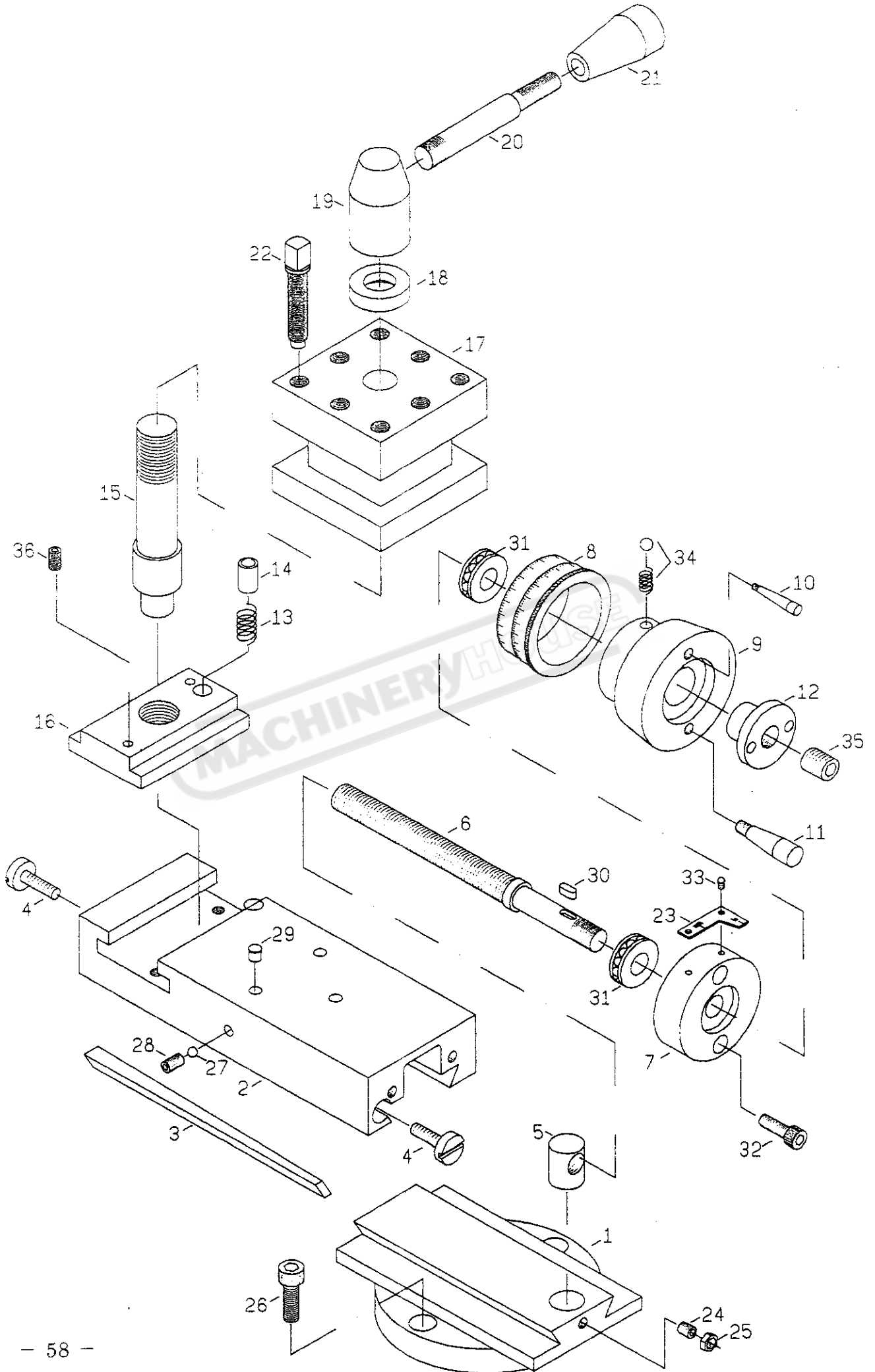

TOP-SLIDE

REF.NO.	PART NO.	DESCRIPTION	Q'TY	REMARKS
1	2420	SWIVEL SLIDE	1	
2	2421	TOP-SLIDE (T-SLOT)	1	
3	2422	GIB	1	
4	2423	SCREW	2	
5	2424	NUT	1	
6	2425	LEAD SCREW	1	
7	2426	BRACKET	1	
8	2427	INDEXING RING	1	
9	2428	HANDWHEEL	1	
10	2429	GRIP (LONG)	1	
11	2430	GRIP (SHORT)	1	
12	2416	NUT	1	
13	2442	SPRING	1	
14	2431	PIN	1	
15	2432	BOLT	1	
16	2441	T-SLOT NUT	1	
17	2433	4-WAY TOOL POST	1	
18	2434	WASHER	1	
19	2435	HUB	1	
20	2436	LEVER	1	
21	2437	PVC KNOB	1	
22	2438	SCREW (3/8 IN)	8	
23	2443	DIAL	1	
24	2463	SET SCREW (6mmx12mm)	1	
25	2444	NUT	1	
26	2462	CAP SCREW (8mmx16mm)	2	
27	2445	STEEL BALL	1	
28	2469	SCREW	1	
29	2450	OIL CAP (1/4 IN)	3	
30	2464	KEY (4mmx10mm)	1	
31	2465	THRUST BEARING (51101)	2	
32	2466	CAP SCREW (6mmx25mm)	2	
33	2446	NAIL (2mm)	2	
34	2467	STEEL BALL & SPRING	1	
35	2455	SCREW (12mmx12mm)	1	
36	2468	SET SCREW	2	

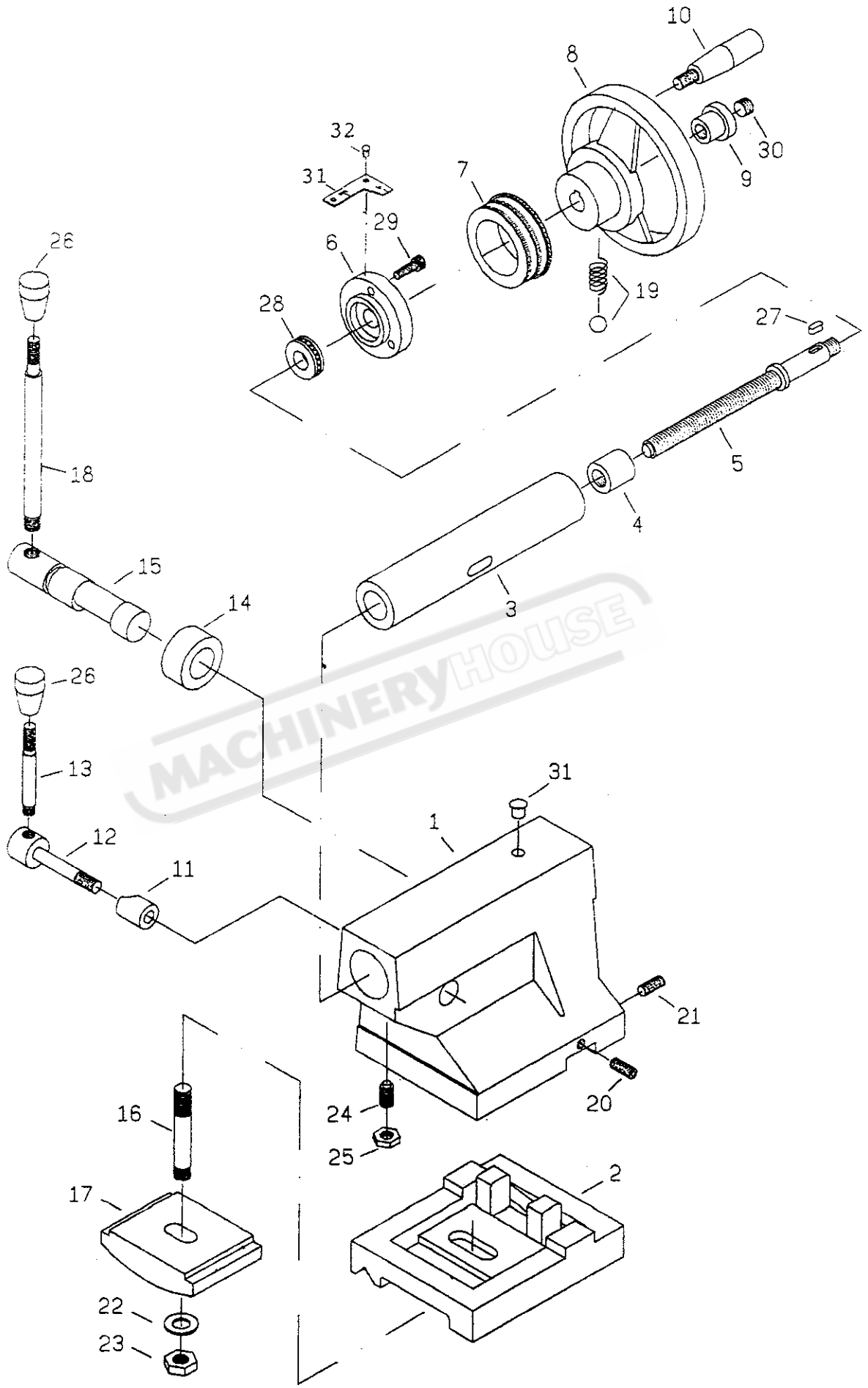

TAILSTOCK

REF.NO.	PART NO.	DESCRIPTION	Q'TY	REMARKS
1	2501	TAILSTOCK CASTING	1	
2	2502	ATILSTOCK BASE	1	
3	2503	TAILSTOCK BARREL	1	
4	2504	NUT	1	
5	2505	FEED SCREW	1	
6	2506	BRACKET	1	
7	2507	DIAL	1	
8	2508	HANDWHEEL	1	
9	2509	NUT	1	
10	2510	HANDLE	1	
11	2511	NUT	1	
12	2512	SHAFT	1	
13	2513	LEVER	1	
14	2514	COLLAR	1	
15	2515	CAM SHAFT	1	
16	2516	CLAMP STUD	1	
17	2517	CLAMP	1	
18	2518	CLAMP HANDLE LEVER	1	
19	2519	STEEL BALL & SPRING	1	
20	2520	SET SCREW (8mmx30mm)	2	
21	2521	SET SCREW (8mmx30mm)	2	
22	2522	WASHER	1	
23	2523	NUT	1	
24	2524	CAP SCREW (8mmx20mm)	1	
25	2525	NUT	1	
26	2526	PVC KNOB	2	
27	2528	KEY (5mmx12mm)	1	
28	2529	THRUST BEARING(2902)	1	
29	2530	CAP SCREW (6mmx20mm)	3	
30	2531	SCREW (12mmx12mm)	1	
31	2527	DIAL	1	
32	2532	SCREW(3/16"x3/8")	2	
33	2533	OIL CAP(1/4")	1	

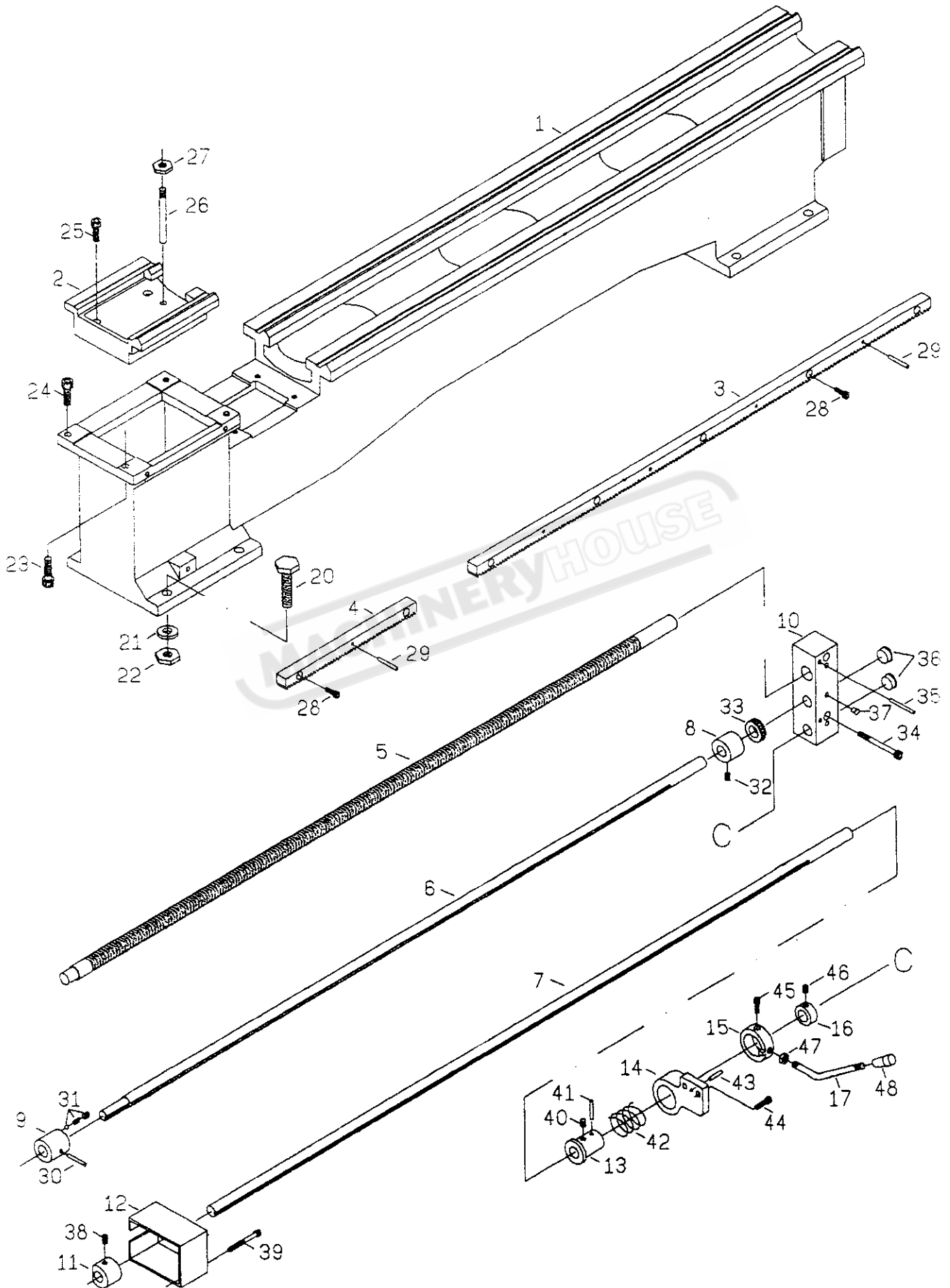

RE

BED RACK LEAD SCREW AND SHAFTS

REF.NO.	PART NO.	DESCRIPTION	Q'TY	REMARKS
1	2601	BED	1	
2	2602	GAP	1	
3	2603	RACK	1	
4	2604	RACK	1	
5	2605	LEAD SCREW (4 T.P.I.)(4 MM)	1	
6	2606	SHAFT	1	
7	2607	FOR/REV CONTROL.THIRD-ROD SHAFT	1	
8	2609	COLLAR	1	
9	2608	COLLAR	1	
10	2617	END BRACKET	1	
11	2611	BUSH	1	
12	2610	BOX	1	
13	2612	BUSHING	1	
14	2613	BRACKET	1	
15	2614	BUSH	1	
16	2615	BUSH	1	
17	2616	LEVER	1	
18	2630	PVC KNOB	1	
20	2634	SCREW (CAP 1/2"x2")	6	
21	2621	WASHER	6	
22	2622	NUT	6	
23	2623	SCREW (CAP 10mmx40mm)	2	
24	2624	SCREW (CAP 10mmx35mm)	2	
25	2632	SCREW (CAP 10mmx35mm)	4	
26	2633	SCREW TAPER PIN	2	
27	2627	NUT	2	
28	2636	SCREW (CAP 6mmx20mm)	6	
29	2635	PIN (5mmx28mm)	4	
30	2637	SCREW (SET 8mmx12mm)	1	
31	2638	STEEL BALL AND SPRING	2	
32	2639	SCREW (SET 8mmx10mm)	1	
33	2640	THRUST (#51104)	1	
34	2651	SCREW (8mmx60mm)	2	
35	2650	PIN (5mmx50mm)	2	
36	2658	PLUG	2	
37	2649	OIL CUP (1/4")	3	
38	2642	SCREW (SET 8mmx10mm)	1	
39	2641	SCREW (CAP 6mmx16mm)	2	
40	2628	SCREW (SET 6mmx16mm)	1	
41	2629	PIN (5mmx28mm)	1	
42	2643	SPRING	1	
43	2646	PIN (5mmx28mm)	1	
44	2644	SCREW (CAP 6mmx20mm)	2	
45	2645	SCREW (CAP 6mmx10mm)	1	
46	2648	SCREW (SET 8mmx8mm)	1	
47	2647	NUT	1	

CHUCK GUARD LIMIT SWITCH

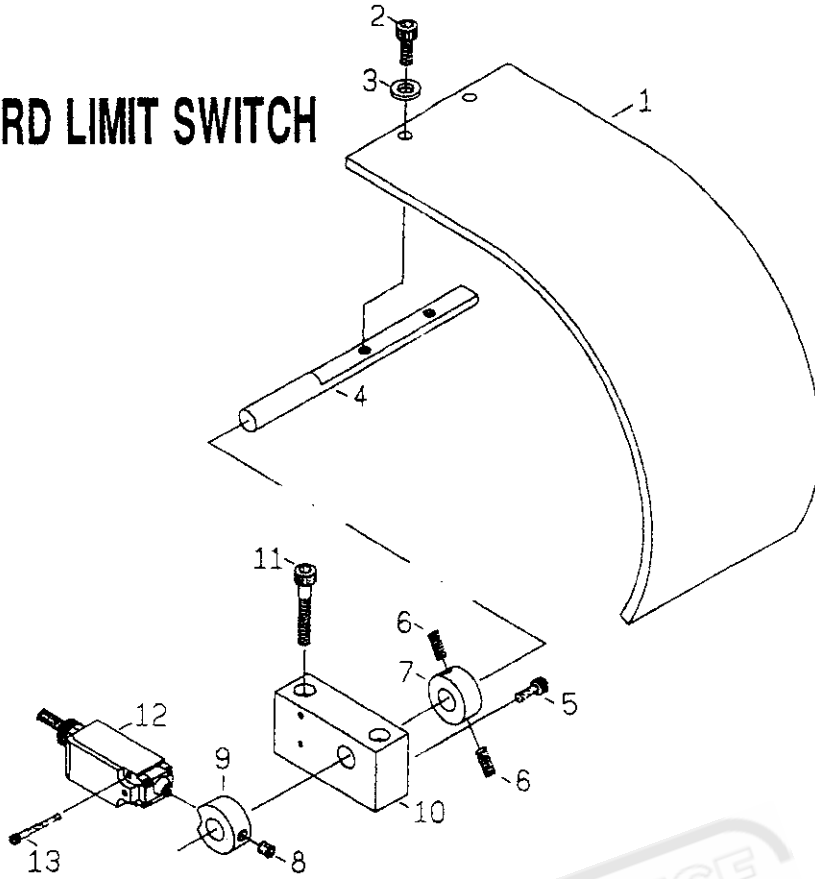

CE COVER

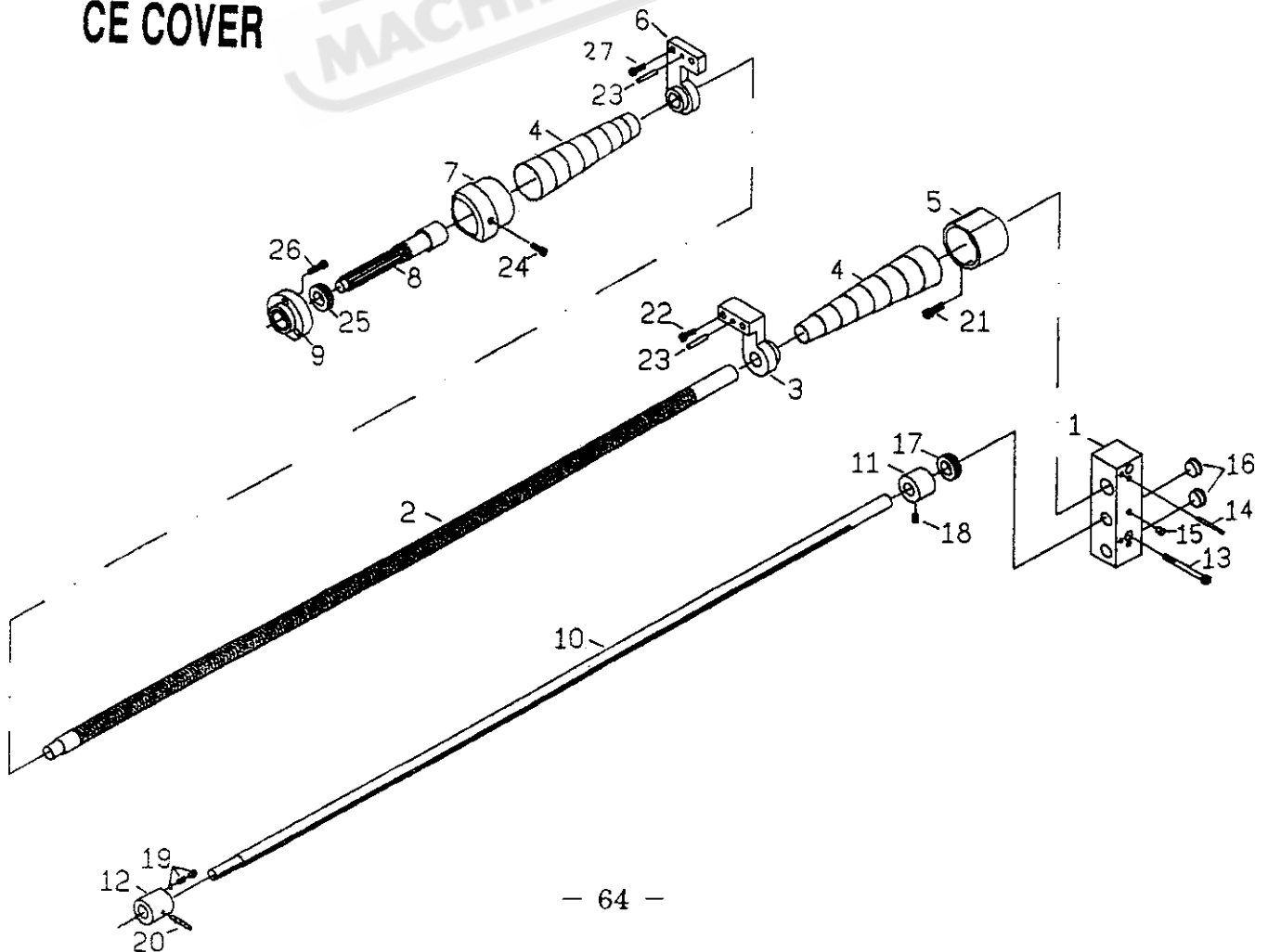

CHUCK GUARD LIMIT SWITCH & CE COVER

REF.NO.	PART NO.	DESCRIPTION	Q'TY	REMARKS
1	2901	COVER	1	
2	2912	CAP SCREW (8mmx20mm)	2	
3	2913	WASHER	2	
4	2914	ROD	1	
5	2911	SCREW (CAP 6mmx16mm)	1	
6	2906	SCREW (SET 8mmx20mm)	2	
7	2907	COLLAR	1	
8	2908	SCREW (SET 8mmx10mm)	1	
9	2909	COLLAR	1	
10	2910	FRAME	1	
11	2903	SCREW (CAP 8mmx55mm)	2	
12	2902	SWITCH AND COVER	1	
13	2904	SCREW (CAP 4mmx30mm)	2	
		<u>CE COVER</u>		
1	2617	END BRACKET	1	
2	2605	LEAD SCREW	1	
3	2625	ARM	1	
4	2668	PROTECTION HOOD	2	
5	2626	BUSH	1	
6	2620	ARM	1	
7	2618	COVER	1	
8	2206	SHAFT	1	
9	2205	COVER	1	
10	2606	SHAFT	1	
11	2609	COLLAR	1	
12	2608	COLLAR	1	
13	2651	SCREW (CAP 8mmx60mm)	2	
14	2650	PIN (5mmx50mm)	2	
15	2649	OIL CUP (1/4")	3	
16	2658	PLUG	2	
17	2667	THRUST (51104)	1	
18	2666	SCREW (SET 8mmx10mm)	1	
19	2665	STEEL BALL SPRING & SCREW	2	
20	2664	SCREW (SET 8mmx12mm)	1	
21	2661	SCREW (CAP 6mmx20mm)	2	
22	2663	SCREW (CAP 8mmx50mm)	2	
23	2653	PIN (5mmx50mm)	2	
24	2662	SCREW (CAP 8mmx16mm)	1	
25	2263	THRUST (51105)	1	
26	2255	SCREW (CAP 6mmx20mm)	3	
27	2660	SCREW (CAP 8mmx30mm)	2	

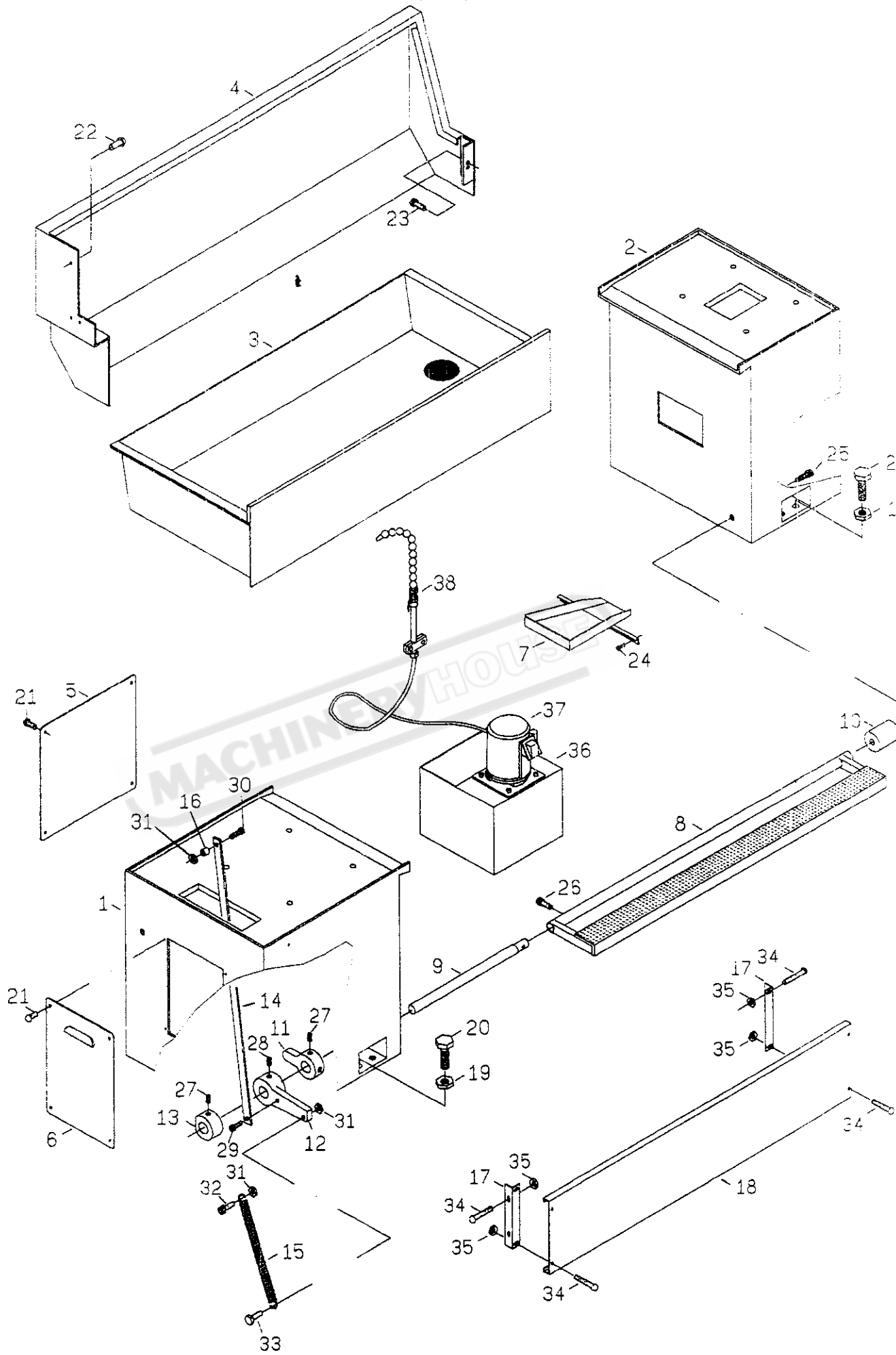

CABINET AND PANELS, PUMP SYSTEM

REF.NO.	PART NO.	DESCRIPTION	Q'TY	REMARKS
1	2701	LEFT PEDESTAL HEAD-END	1	
2	2702	RIGHT PEDESTAL TAIL-END	1	
3	2704	CHIP PAN	1	
4	2705	SPLASH GUARD	1	
5	2709	COVER	1	
6	2708	COVER	1	
7	2707	CHUTE	1	
8	2703	FOOT BRAKE PEDAL	1	
9	2715	CONNECTOR SHAFT	1	
10	2716	COLLAR	1	
11	2714	LEVER	1	
12	2713	LEVER	1	
13	2712	COLLAR	1	
14	2711	BAR	1	
15	2745	SPRING	1	
16	2730	WASHER	1	
17	2719	BAR	2	
18	2718	CONNECT PLATE	1	
19	2710	NUT	2	
20	2732	SCREW (1/2"x2")	4	
21	2741	SCREW (6mmx12mm)	8	
22	2737	SCREW (CAP 6mmx12mm)	3	
23	2736	SCREW (CAP 8mmx20mm)	1	
24	2735	SCREW (CAP 6mmx16mm)	2	
25	2734	SCREW (CAP 8mmx20mm)	1	
26	2733	SCREW (CAP 8mmx20mm)	2	
27	2742	SCREW (SET 10mmx20mm)	2	
28	2743	SCREW (SET 10mmx40mm)	2	
29	2731	SCREW (CAP 8mmx10mm)	1	
30	2740	SCREW (8mmx10mm)	1	
31	2746	NUT	3	
32	2738	SCREW (CAP 8mmx25mm)	1	
33	2739	SCREW (8mmx30mm)	1	
34	2747	SCREW (6mmx16mm)	8	
35	2748	NUT	8	
36	2706	TANK	1	
37	2717	PUMP (1/8 HP)	1	
38	2720	HOSE	1	

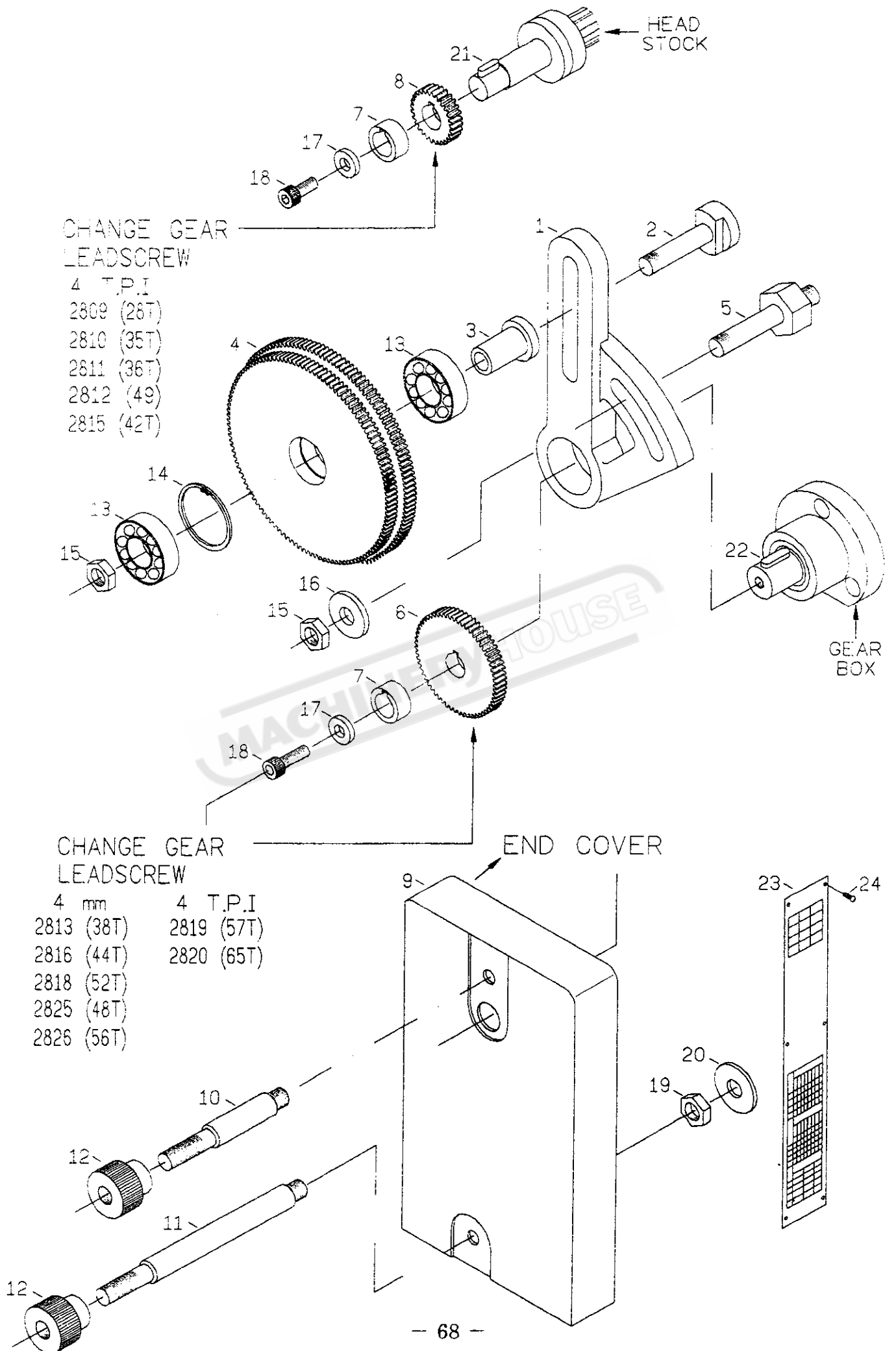

CHANGE GEAR
LEADSCREW

- 4 T.P.I
- 2809 (28T)
- 2810 (35T)
- 2811 (36T)
- 2812 (49)
- 2815 (42T)

CHANGE GEAR
LEADSCREW

- 4 mm 4 T.P.I
- 2813 (38T) 2819 (57T)
- 2816 (44T) 2820 (65T)
- 2818 (52T)
- 2825 (48T)
- 2826 (56T)

END COVER

GEAR
BOX

SWING FRAME & GEARS, END COVER

REF.NO.	PART NO.	DESCRIPTION	Q'TY	REMARKS
1	2801	SWING FRAM	1	
2	2802	BOLT	1	
3	2803	COLLAR	1	
4	2804	GEAR(M1.25x120T,127T)	1	
5	2805	SCREW	1	
6	2808	GEAR(1.25x60T)	1	
7	2806	COLLAR	1	
8	2807	GEAR(1.25x30T)	1	
9	2821	END COVER	1	
10	2822	STUD	1	
11	2824	STUD	1	
12	2823	NUT	2	
13	2833	BEARING(6202Z)	2	
14	2836	CIRCLIP(R 35)	1	
15	2835	NUT	2	
16	2837	WASHER	1	
17	2839	WASHER	2	
18	2840	SCREW(CAP 6mmx16mm)	2	
19	2838	NUT	1	
20	2831	WASHER	1	
21	2830	KEY (5mmx18mm)	1	
22	2841	KEY (5mmx18mm)	1	
23	2827	DATA PLATE	1	
24	2817	SCREW (3/16"x3/8")	6	
25	2809	CHANGE GEAR (M1.25x28T)	1	
26	2810	CHANGE GEAR (M1.25x35T)	1	
27	2811	CHANGE GEAR (M1.25x36T)	1	
28	2812	CHANGE GEAR (M1.25x49T)	1	
29	2815	CHANGE GEAR (M1.25x42T)	1	
30	2813	CHANGE GEAR (M1.25x38T)	1	
31	2816	CHANGE GEAR (M1.25x44T)	1	
32	2818	CHANGE GEAR (M1.25x52T)	1	
33	2825	CHANGE GEAR (M1.25x48T)	1	
34	2826	CHANGE GEAR (M1.25x56T)	1	
35	2819	CHANGE GEAR (M1.25x57T)	1	
36	2820	CHANGE GEAR (M1.25x65T)	1	
37	2814	CHANGE GEAR (M1.25x40T)	1	

STEADY REST AND FOLLOW REST

REF.NO.	PART NO.	DESCRIPTION	Q'TY	REMARKS
1	2917	CASTING	1	
2	2918	CASTING	1	
3	2919	SHAFT	5	
4	2920	SCREW	5	
5	2905	COLLAR	5	
6	2921	HANDLE	5	
7	2922	SHAFT	5	
8	2923	SCREW	1	
9	2924	HANDLE	1	
10	2925	SHAFT	1	
11	2926	SCREW	5	
12	2927	SCREW	5	
13	2928	SPRING PIN	5	
14	2929	SPRING PIN	1	
15	2915	CASTING	1	
16	2916	SCREW	2	

MACHINERYHOUSE

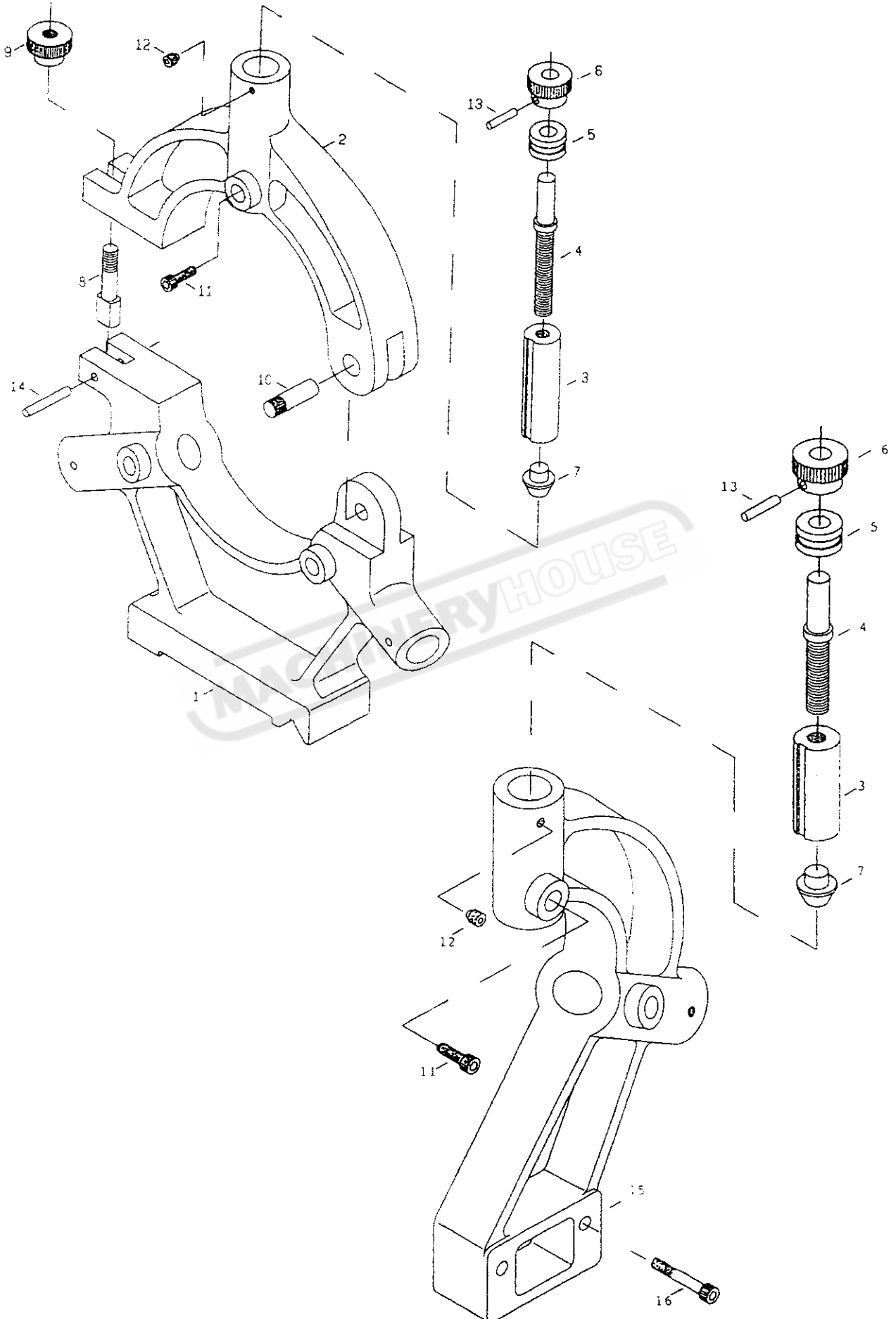

ELECTRIC EQUIPMENTS

CONSTRUCTION

THE ELECTRIC EQUIPMENTS ARE CONSISTS OF SPINDLE MOTOR, CONTROL PANEL, MAGNETIC CONTACTOR, MAGNETIC SWITCH, CONTROL CONDUIT AND TRANSFORMER.

- A. THE SPINDLE MOTOR IS TOTALLY ENCLOSED, 3 PHASES 3.7KW(5HP) 4 POLES.
- B. THE CONTROL PANEL INCLUDES POWER ON AND OFF SWITCHES, COOLANT PUMP SWITCH AND PILOT LAMP.
- C. THE MAGNETIC CONTROL PANEL HAS SPINDLE MOTOR, REVERSIBLE MAGNETIC VALVE. AND SUBSIDIARY MAGNETIC CONTACTOR.
- D. THE FORWARDING AND REVERSING RUNNING CONTROL LEVER IS CONTROLLED BY A MICRO SWITCH.
- E. A MICRO SWITCH FOR FOOT BRAKE PEDAL IS FITTED SEPARATELY. WHEN THE PEDAL IS USED, THE MAGNETIC SWITCH ON SPINDLE MOTOR WILL CUT OFF AUTOMATICALLY.

RUNNING STEPS

1. A POWER SWITCH IS FITTED ON THE CONTROL PANEL. PUT THIS SWITCH ON POSITION "ON" THEN THE PILOT LAMP IS LIGHTING.
2. PUSH OR PULL THE FORWARDING AND REVERSING RUNNING CONTROL LEVER THEN THE SPINDLE STARTS TO RUN.
3. UPON EMERGENCY STOP IS NEED, USE THE FOOT BRAKE PEDAL THEN THE SPINDLE MOTOR WILL CUT OFF AUTOMATICALLY. MEANWHILE, THE BRAKE IS ACTIVATED TO STOP RUNNING OF THE SPINDLE.
4. SUALLY, WHEN THE MACHINE NEEDS STOP, TO PUT ONLY THE LEVER CONTROL SWITCH ON THE MIDDLE POSITION. THUS, THE MAGNETIC SWITCH WILL CUT OFF AND THE MACHINE WILL SOP RUNNING.
5. UPON OPERATION IS COMPLETED, BE SURE TO PUT THE POWER SWITCH LOCATED AT THE CONTROL PANEL ON POSITION "OFF".

DISMOUNTING OF THE GAP BED

FIRST, TO TAKE OFF THE FOUR SCREWS MOUNTED ON THE SURFACE AND REMOVE THE PIN IN THE MIDDLE THEN MOVE THE GAP BED HORIZONTALLY AND GET IT DOWN. BE CAREFUL TO ITS PIN AND EDGES. KEEP THE GAP BED CAREFULLY AND DO NOT HIT IT. TO FOLLOW THE OPPOSITE STEPS FOR MOUNTING THE GAP BED BACK TO THE MACHINE. BEFORE MOUNTING, THE BED WAYS AD THE GAP HAVE TO BE CLEANED.

NOTES



1. BE SURE TO OPERATE ALWAYS THE MACHINE CAREFULLY AND KEEP IT WITH GOOD MAINTENANCE. IF SO, THE MACHINE'S LONGEVITY AND PRECISION CAN BE ASSURED.
2. EVERY DAY, WHEN THE OPERATION IS COMPLETED, BE SURE TO CLEAN OUT THE CHIPS LEAVE ON THE MACHINE AND OIL THE SLIDE WAYS TO PREVENT RUST AND MEANTIME, TURN OFF THE POWER SWITCH.
3. EVERY DAY, BEFORE OPERATION, BE SURE TO CHECK OIL LEVEL FOR OIL VOLUME AND FILL IT UP IF NECESSARY. ESPECIALYY, THE OIL SUPPLEMENT FOR FEED BOX IS EASILY FOGOTTEN BY THE OPERATOR. THE BEST WAY IS FEEDING OIL DAILY IN THE MORNING AND IN THE AFTERNOON SEPARATELY BEFORE RUNNING OF THE MACHINE.
4. FOR A NEW MACHINE, AFTER OPERATION OF 3 MONTHS, THE OIL IN HEADSTOCK HAS TO BE REPLACED OR FILTERED IF IT TO BE USED REPEATEDLY. THUS, TO PROTECT THE GEARS INSIDE OF THE HEADSTOCK AND LESSEN THE NOISE.
5. IF HEADSTOCK IS OVER HEATED, HIGH WOBBLER, OIL LEAKED AND OIL SHORTED, THEN PLEASE STOP THE MACHINE IMMEDIATELY AND ARRANGE A PEOPLE TO SOLVE THE PROBLEM. WHEN THE PROBLEM IS SOLVED, THEN THE MACHINE CAN BE RUN AGAIN. OTHERWISE, MORE BIGGER PROBLEM IS COMING BECAUSE THE LITTLE CASE NOT CURED.
6. WHILE CLAMPING THE WORKPIECE, PLEASE DO NOT HIT IT BY HAMMER OR WEIGHT OTHERWISE THE SPINDLE WILL BE COLLIDED AND THE ACCURACY OF PRECISION IS EFFECTED.
7. AFTER OPERATION, THE HAND TOOLS, CUTTING TOOLS AND CLAMPING KITS SHOULD BE PUT ON APPROPRIATE POSITIONS. PLEASE DO NOT PUT ANY THING ON THE SLIDE WAYS OR BED WAY TO PREVENT COLLISION TO THE SLIDE WAYS AND EFFECT TO THE PRECISION.
8. BESIDES THE OPERATOR, PLEASE DO NOT LET ANYBODY ADJUST OR MOVE THE POSITION OF HANDLES OR CONTROLLING LEVERS, OR OPERATE THE MACHINE.
9. MAKE A TIME TABLE OF MACHINE MAINTENANCE AND MAINTAIN IT PERIODICALLY ACCORDING TO THE SCHEDULE, AND THUS TO BENEFIT THE PRECISION AND LONGEVITY OF THE MACHINE.

TROUBLE SHOOTING

TROUBLES	FACTORS	REMEDY
HEADSTOCK BEARINGS ARE OVER HEATED	<ol style="list-style-type: none"> 1. OIL LEVEL IN HEADSTOCK IS TOO LOW. 2. OIL VISCOSITY IS WRONG. 3. OIL PIPE IS OBSTRUCTED OR LEAKED. 4. MAIN SPINDLE IS WOBBLING OR OVER LOADED. 5. OIL FILTER IS OBSTRUCTED. 	<ol style="list-style-type: none"> 1. CHECK IF OIL LEVEL IN CORRECT POSITION AND FILL IT UP IF NECESSARY. 2. CHECK IF THE RECOMMENDED OIL IS USED. 3. CLEAN OIL PIPE OR REPLACE A NEW ONE IF NEED. 4. CHECK IF THE SPINDLE IS LOCKED UPON FREE RUNNING. 5. FILTER THE OIL OR REPLACE NEW OIL.
OIL LEAKAGE ON SPINDLE FLANGE OR GEAR BOX COVER	<ol style="list-style-type: none"> 1. BOLT IS LOOSE. 2. OIL PACKING IS WORN. 3. OIL VOLUME IS OVER. 4. OIL SEAL IS CRACKED. 5. THE SURFACE FINISH IS COARSE. 	<ol style="list-style-type: none"> 1. LOCK THE BOLT. 2. REPLACE THE PACKING. 3. LOWER THE OIL. 4. REPLACE OIL SEAL. 5. CORRECT THE FINISH.
CHATTER	<ol style="list-style-type: none"> 1. WORKPIECE IS NOT CLAMPED SECURELY. 2. WORKPIECE LEAVES TOO LONG AT LEFT SIDE OF THE CLAMPING POSITION. 3. IMPROPER CUTTING TOOL IS USED. 4. CUTTING TOOL IS TOO HIGH OR TOO LOW TO THE CENTER OF SPINDLE. 5. CHIP IS NOT REMOVED FREELY FROM THE TOOL. 6. WORKPIECE IS TOO LONG. 	<ol style="list-style-type: none"> 1. CLAMP IT SECURELY. 2. LESSEN THE LENGTH TO AVOID Wobble HAPPENED. 3. SELECT SUITABLE CUTTING TOOL ACCORDING TO MATERIAL OF WORKPIECE AND THE CUTTING SPEED. FOR SMALL DIAMETER OF WORKPIECE, A SMALL ANGLE OF CUTTING TOOL TO BE USED. IF OPPOSITE, USE THE BIG ANGLE OF CUTTING TOOL. 4. ADJUST THE CUTTING TOOL TO THE CENTER OF SPINDLE. 5. MOUNT A CHIP CUTTER OR ADJUST THE FRONT ANGLE OF CUTTING TOOL. 6. USE A CENTER TO SUPPORT LONGER WORKPIECE.
BENT FINISH ON LONG WORKPIECE CUTTING	<ol style="list-style-type: none"> 1. MATERIAL IS OVER HEATED. 2. DEEP CUT IS MADE. 3. HOT IS HAPPENED TO THE CENTER AND WORKPIECE. 	<ol style="list-style-type: none"> 1. USE COOLANT OIL FOR CUTTING. 2. REDUCE THE DEPTH FOR EACH CUTTING. 3. USE ROLLING CENTER FOR HIGH SPEED RUNNING.
PRECISION IS GETTING WORSE	<ol style="list-style-type: none"> 1. WORKPIECE IS NOT BALANCE CLAMPED. 2. ALWAYS HIT THE WORKPIECE BY HAMMER. 3. CENTER OF SPINDLE IS NOT ALIGNMENT WITH THE CENTER OF TAILSTOCK. 4. MACHINE IS OUT OF THE HORIZONTAL. 	<ol style="list-style-type: none"> 1. CLAMP WORKPIECE IN BALANCE 2. DO NOT HIT IT BY HAMMER. 3. ADJUST THE TAILSTOCK TO ALIGNMENT WITH THE CENTER OF SPINDLE. 4. CHECK PERIODICALLY HORIZONTAL OF MACHINE.
LEVER SWITCH IS HARD OPERATED	THE OPERATOR IS NOT FAMILIAR WITH OPERATION OF THE MACHINE.	THE LEVER SWITCH IS FITTED WITH A SAFETY DEVICE. DURING OPERATION, THE LEVER MUST BE MOVED SLIGHTLY TO RIGHT THEN OPERATE UPWARD OR DOWNWARD FOR RUNNING THE SPINDLE CLOCKWISE AND ANTICLOCKWISE.

TOLERANCE PERMISSIBLE DIAGRAM

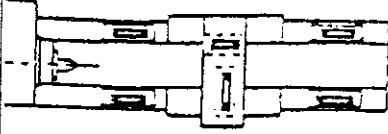
1.ACCURACY TEST.(mm)

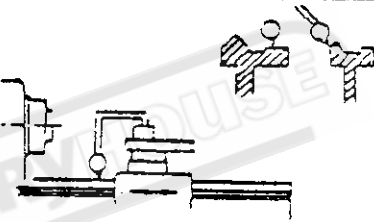
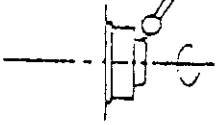
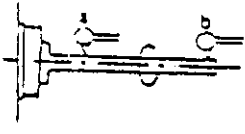
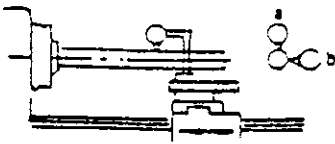
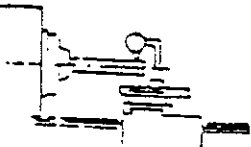
NO.	INSPECTION ITEM		DIAGRAM	TOLERANCE PERMISSIBLE
1	Straightness of bed slideway	a.Longitudinal direction (In vertical plane)		0.04
		b.Transverse direction (In vertical plane)		0.04
2	Parallelism of bed slideways.			0.02
3	Spindle nose runout			0.01
4	Spindle taper hole runout	a.Nearest spindle nose		0.01
		b.At a distance of 300mm		0.02
5	Parallelism of center line of main spindle to longitudinal motion of carriage	a.In vertical plane		0.025
		b.In horizontal plane		0.025
6	Movement of compound slide parallel with main spindle in vertical plane (Hand feed)			0.01/150

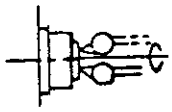
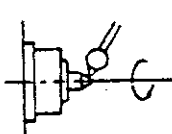
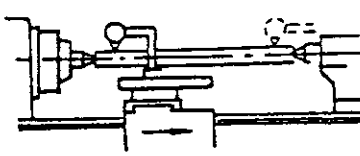
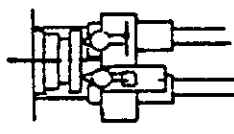
NO.	INSPECTION ITEM	DIAGRAM	TOLERANCE PERMISSIBLE
7	Main spindle for axial slip. measured at 2 points, displaced by 180°		0.015
8	True running of center point of main spindle.		0.015
9	Parallelism of tailstock spindle with bed ways.	a. In vertical plane (Front end rising)	0.015/100
		b. In horizontal plane (Front end inclined to wards the direction of tool pressure.)	0.015/100
10	Parallelism of bed ways with center line of tailstock spindle hole.	a. In vertical plane (Free end of mandrel rising)	0.02/300
		b. In horizontal plane (Free end of mandrel inclined to wards tailstock end)	0.02/300
11	Difference in center height between headstock and tailstock (Mandrel rising towards tailstock end)		0.025
12	Squareness of motion of cross slide with center line of main spindle		0.02/300
13	Parallelism of center line of lead screw end bearing to carriage slide ways	a. In vertical plane	0.1
		b. In horizontal plane	0.1
14	Diviations in alignment of center line of lead screw end bearing with center line of half nut.	a. In vertical plane	0.15
		b. In horizontal plane	0.15

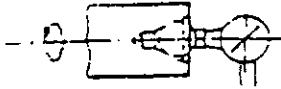
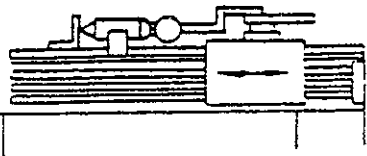
NO	INSPECTION	DIAGRAM	TOLERANCE PERMISSIBLE
15	Axial displacement of lead screw by turning		0.01
16	Pitch error of lead screw		0.03/300

2. PRACTICAL

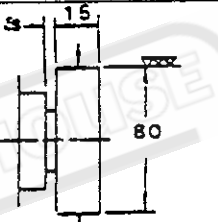
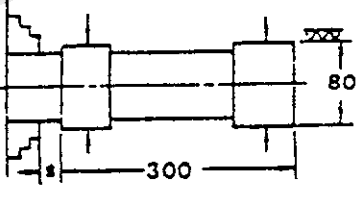
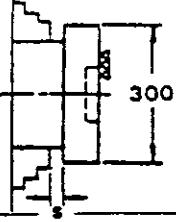
NO.	JESTING ITEM	DIAGRAM	TOLERANCE PERMISSIBLE
1	Accuracy of outside turning		0.01
2	Accuracy of cylindrical turning		0.025
3	Accuracy of face turning		0.02

3. CHECK OF MOTOR SPECIFICATION

ITEM	HP	Ph	V	Hz	R.P.M.
Rating	2 / 3	1 / 3		50 / 60	1420 / 1700
Actual	✓	✓	415	✓	✓